

ROBOTICS

# Product specification

## IRT 710

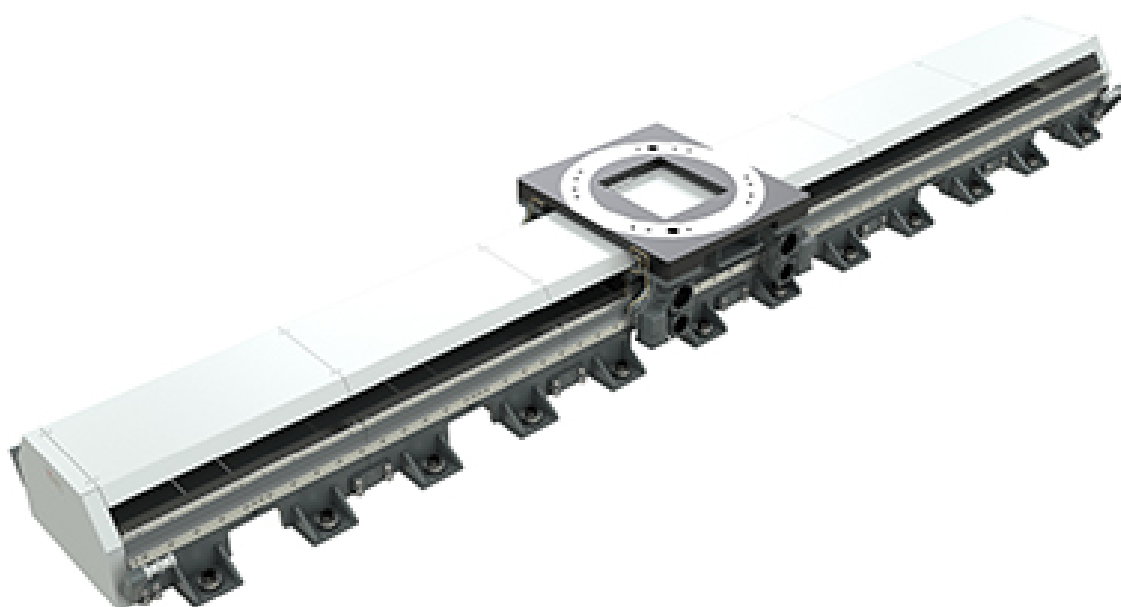

Trace back information:  
Workspace Systems version a35  
Checked in 2022-12-13  
Skribenta version 5.5.019

# **Product specification**

**IRT 710**

**IRC5**

**Document ID: 3HKA00000191844-001**

**Revision: A**

The information in this manual is subject to change without notice and should not be construed as a commitment by ABB. ABB assumes no responsibility for any errors that may appear in this manual.

Except as may be expressly stated anywhere in this manual, nothing herein shall be construed as any kind of guarantee or warranty by ABB for losses, damage to persons or property, fitness for a specific purpose or the like.

In no event shall ABB be liable for incidental or consequential damages arising from use of this manual and products described herein.

This manual and parts thereof must not be reproduced or copied without ABB's written permission.

Keep for future reference.

Additional copies of this manual may be obtained from ABB.

Original instructions.

© Copyright 2022 ABB. All rights reserved.  
Specifications subject to change without notice.



# Table of contents

Overview of this specification .....	7
<b>1 Description</b> .....	<b>9</b>
1.1 Structure .....	9
1.1.1 Introduction .....	9
1.1.2 Technical data .....	11
1.1.3 Information labels .....	17
1.2 Standards .....	18
1.2.1 Applicable standards .....	18
1.3 Installation .....	19
1.3.1 Introduction to installation and commissioning .....	19
1.3.2 On-site installation .....	20
1.3.2.1 Track motion IRT 710 overview .....	20
1.3.2.2 Track motion IRT 710 layout .....	25
1.3.2.3 Foundation .....	27
1.3.2.4 Screw joints .....	33
1.3.2.5 Assembly of the manipulator .....	34
1.3.3 Cabling of the IRT 710 .....	36
1.3.4 Specifications of the movement cables .....	38
1.3.5 Connectors on IRC5 controller .....	39
1.3.6 Connectors on Drive Module .....	41
1.3.7 Assembly the cable of the additional axes SMB .....	42
1.3.8 Grounding point .....	43
1.3.9 Lubrication .....	45
1.3.9.1 Activating the automatic lubrication system .....	45
1.3.9.2 Lubrication feedback (optional) .....	46
1.4 Calibration .....	47
1.4.1 Introduction to calibration .....	47
1.4.1.1 Introduction and calibration terminology .....	47
1.4.1.2 Calibration methods .....	48
1.4.1.3 When to calibrate .....	49
1.4.2 Synchronization marks and track motion movement directions .....	50
1.4.2.1 Synchronization marks and synchronization position for track motions ...	50
1.4.3 Calibrating with Axis Calibration method .....	54
1.4.3.1 Description of Axis Calibration .....	55
1.4.3.2 Calibration tools for Axis Calibration .....	57
1.4.3.3 Installation locations for the calibration tools .....	59
1.4.4 Pin calibration .....	60
1.5 Motion .....	61
1.5.1 Track type .....	61
1.5.2 Working range .....	62
1.5.3 Performance .....	78
1.5.4 Velocity .....	79
1.5.5 Positioning time .....	80
1.5.6 Stopping distance/time .....	81
1.5.7 Thermal performance .....	82
1.6 Maintenance and troubleshooting .....	83
<b>2 Specification of variants and options</b> .....	<b>85</b>
2.1 Introduction to variants and options .....	85
2.2 Track motion type .....	86
2.3 CARRIAGE BASICS (NUMBER 1/2/3/4) .....	88
<b>Index</b> .....	<b>105</b>

**This page is intentionally left blank**

# Overview of this specification

## About this product specification

This product specification describes the performance of the track motion or a complete family of track motion in terms of:

- The structure and dimensional prints
- The fulfilment of standards, safety, and operating equipment
- The mounting or extra equipment and the motion
- The specification of available variants and options

The specification covers the track motion using the IRC5 controller and RW 6.14.

## References

Documentation referred to in the manual, is listed in the table below.

Document name	Document ID
<i>Safety manual for robot - Manipulator and IRC5 or OmniCore controller</i> <sup>i</sup>	3HAC031045-001
<i>Product manual - IRC5</i>	3HAC021313-001
<i>Technical reference manual - System parameters</i>	3HAC050948-001

<sup>i</sup> This manual contains all safety instructions from the product manuals for the manipulators and the controllers.

## Revisions

Revision	Description
A	First edition

**This page is intentionally left blank**

# 1 Description

## 1.1 Structure

### 1.1.1 Introduction

---

#### Overview of IRT710 New Track Motion

The IRT 710 is a new large modular platform for large size robots (up to IRB 7600) and handling applications.

The IRT 710 new track motion had high degree of modularity by the following aspects:

- Different process applications
- Different robots or fixture transfer
- Different travel length
- Optimize performance based on actual load via dynamic model
- Flexibility to add functionality or extend working range also at a later stage

---

#### Operating system

IRT 710 is prepared for the IRC5 controller and robot control software, RobotWare. RobotWare supports every aspect of the robot system, such as motion control, development and execution of application programs, communication etc. See *Product specification - Controller IRC5 with FlexPendant*.

---

#### Safety

Safety standards require the connection of IRT 710 to the robot system and are valid for complete robot, manipulator and controller.

---

#### Additional functionality

For additional functionality, the robot can be equipped with optional software for application support - for example welding, communication features - network communication - and advanced functions such as multitasking, sensor control etc. For a complete description on optional software, see the *Product specification - Controller software IRC5*

---

#### Performance

IRT 710 and its respective robot is a seven-axis dynamic model. ABB's unique QuickMove and TrueMove can be fully exploited, which means optimal movement for the robot and the track with actual load. Furthermore, path accuracy and speed are optimized.

*Continues on next page*

# 1 Description

## 1.1.1 Introduction

*Continued*

### Identification plate



#### Tip

Always try to determine if the goods are as ordered, and that the package is not damaged before unpacking.

To identify the delivery, check the identification plate and compare it to the delivery note.

The identification plates are shown in the figure.

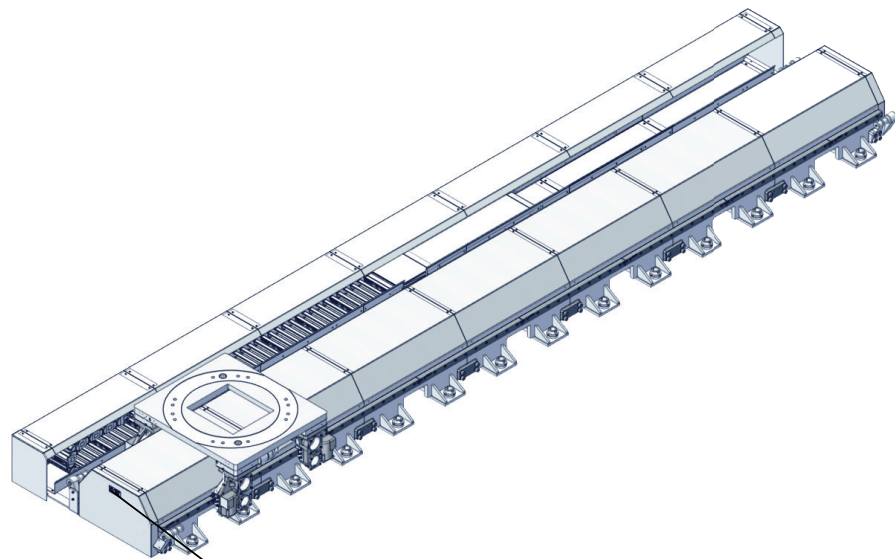

<b>ABB</b>	ABB Engineering (Shanghai) Ltd. No.4528, Kangxin Highway, Pudong New District, Shanghai, CN
Product Name: Track Motion	Date Of Manufacturing:
Model Type: IRT710	Variant: IRT710-
Serial No.:	Payload: See Instruction
Weight Of Carriage 1 (Kg):	Weight Of Carriage 2 (Kg):
Weight Of Carriage 3 ( g):	Weight Of Carriage 4 (Kg):
Weight Of Track (Kg):	Total Weight (Kg):

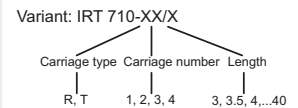

xx2200000408

\*: R represents Robot; T represents Transfer.

1.1.2 Technical data

Protection standards

Protection type	Protection class
Standard	IP65 <sup>i</sup>

<sup>i</sup> Only the electrical parts.

Explosive environments

The track motion must not be located or operated in an explosive environment.

Required space for installation



Note

The tables only give the space that the track motion itself requires. In addition there probably needs to be additional space at the ends of the track motion at the installation site. Add space as required.

Formula for carriage tracks

Required space for carriage tracks is determined with the following formula:

$$\text{Required space (mm)} = 1000 \times N^1 + 2 \times 66 + 500^2$$

Dimensions

Without external cable chain

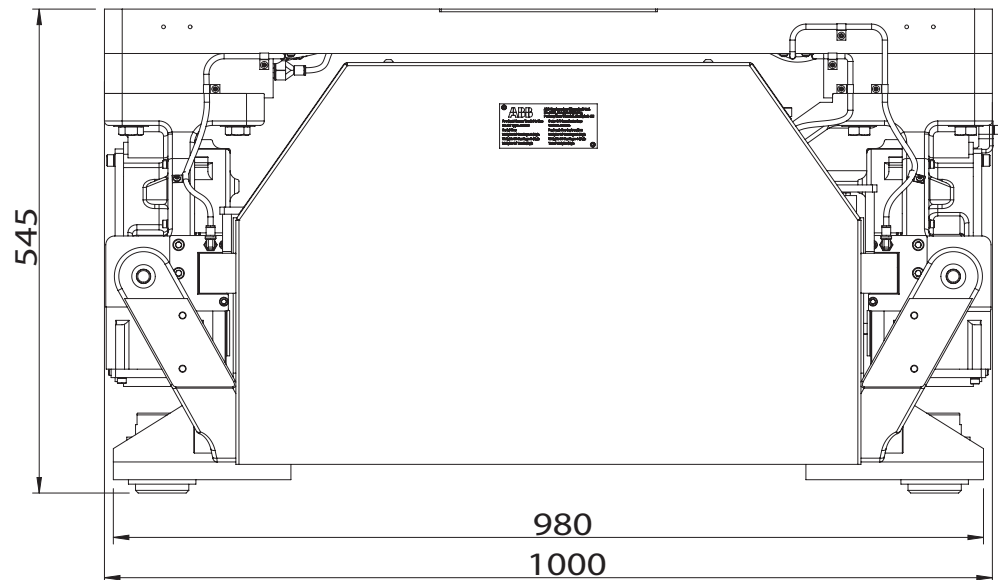

xx2200001281

<sup>1</sup> Value of N is equal to the number of sections.

<sup>2</sup> Valid if the length is N + 0.5 m

Continues on next page

# 1 Description

## 1.1.2 Technical data

Continued

With external cable chain

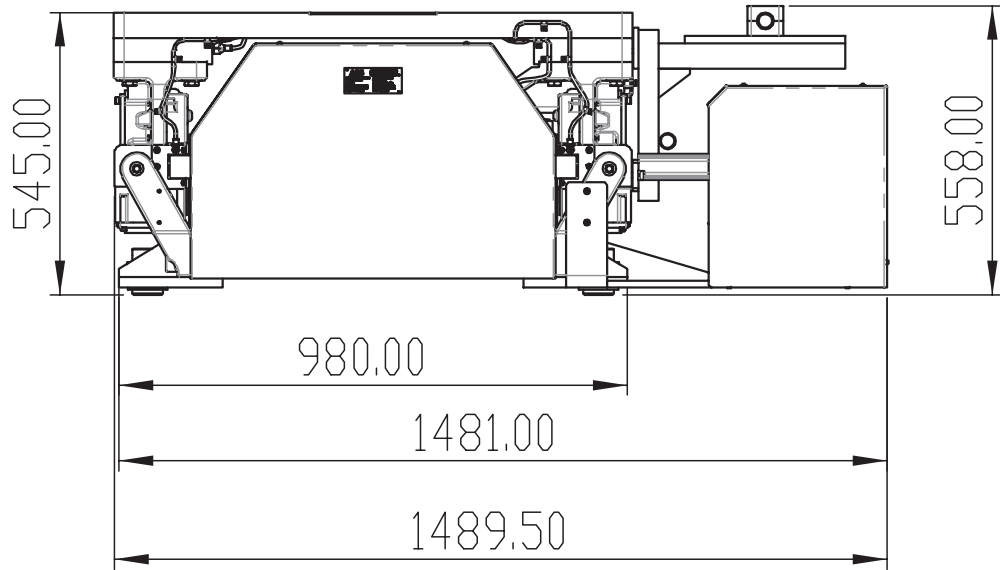

xx2200000400

### Requirements, foundation

The table shows the requirements for the foundation where the weight of the installed robot is included:

Requirement	Value	Note
Flatness of foundation surface	1 mm/m (movement direction) 0.5 mm/m (Perpendicular to movement direction) Overall height difference $\leq 10$ mm	Flat foundations give better repeatability of the resolver calibration compared to original settings on delivery from ABB. The value for levelness aims at the circumference of the anchoring points in the robot base.

### Mechanical stops

There are no adjustable mechanical stops on the IRT 710. This needs to be considered while doing a risk assessment of the complete installation, the track can however be order in different lengths.

### Weight, robot

For the detailed weight of each robot, see the robot product manual.

### Weight, pedestal

Robot Pedestal	Height	Weight	IRB 7600	IRB 760	IRB 6660	IRB 6650S	IRB 6700	IRB 6620	IRB 660	IRB 460	IRB 4400	IRB 4600
3HKA00000190345	250 mm	213 kg	√	√	√	√	√	√	√	√		
3HKA00000190346	500 mm	288 kg					√	√	√	√		
3HKA00000190348	250 mm	220 kg									√	√

Continues on next page



# 1 Description

## 1.1.2 Technical data

*Continued*

Robot Pedestal	Height	Weight	IRB 7600	IRB 760	IRB 6660	IRB 6650S	IRB 6700	IRB 6620	IRB 660	IRB 460	IRB 4400	IRB 4600
3HKA00000190349	500 mm	276 kg									√	√
3HKA00000190350	750 mm	331 kg										√

### Weight, track motion excluding harness and pedestal

The following table shows the weight of the track motion excluding harness and pedestal.



#### Note

This weight include the harness for the track motor (power and signal). But do not include the harness which connected to the robot or tooling, such as the robot power cable, CP/CS harness, welding cables, media pipes and etc.



#### Tip

There are three types carriages used in IRT 710. For more information, see *Carriage overview* chapter in product manual.

The following table takes the large robot carriage weight into count. If any robot carriage or transfer carriage is used, please minus the corresponding weight. For more information on the carriages weight, see *Weight, Carriages* chapter in product manual.

Carriage NO.	1 Carriage		2 Carriages		3 Carriages	4 Carriages
	only internal cable tray (Kg)	only external cable tray (Kg)	only internal cable tray (Kg)	only external cable tray (Kg)	Standard (Kg)	Standard (Kg)
3	1611	1783	X	X	X	X
3.5	1719	1891	X	X	X	X
4	1945	2160	2509	2767	X	X
4.5	2053	2268	2617	2875	X	X
5	2276	2534	2846	3147	X	X
5.5	2384	2642	2954	3255	X	X
6	2610	2911	3177	3521	4039	X
6.5	2718	3019	3285	3629	4156	X
7	2941	3285	3514	3901	4422	X
7.5	3049	3393	3622	4009	4530	X
8	3275	3662	3845	4275	4796	5409
8.5	3383	3770	3953	4383	4913	5517
9	3606	4036	4182	4655	5179	5783
9.5	3714	4144	4290	4763	5287	5903
10	3940	4413	4513	5029	5553	6169

*Continues on next page*

# 1 Description

## 1.1.2 Technical data

Continued

Carriage NO.	1 Carriage		2 Carriages		3 Carriages	4 Carriages
	only internal cable tray (Kg)	only external cable tray (Kg)	only internal cable tray (Kg)	only external cable tray (Kg)	Standard (Kg)	Standard (Kg)
10.5	4048	4521	4621	5137	5670	6277
11	4271	4787	4850	5409	5936	6543
11.5	4379	4895	4958	5517	6044	6663
12	4605	5164	5181	5783	6310	6929
12.5	4713	5272	5289	5891	6427	7037
13	4936	5538	5518	6163	6693	7303
13.5	5044	5646	5626	6271	6801	7423
14	5270	5915	5849	6537	7067	7689
14.5	5378	6023	5957	6645	7184	7797
15	5601	6289	6186	6917	7450	8063
15.5	5709	6397	6294	7025	7558	8183
16	5935	6666	6517	7291	7824	8449
16.5	6043	6774	6625	7399	7941	8557
17	6266	7040	6854	7671	8207	8823
17.5	6374	7148	6962	7779	8315	8943
18	6600	7417	7185	8045	8581	9209
18.5	6708	7525	7293	8153	8698	9317
19	6931	7791	7522	8425	8964	9583
19.5	7039	7899	7630	8533	9072	9703
20	7265	8168	7853	8799	9338	9969
20.5	7373	8276	7961	8907	9455	10077
21	7596	8542	8190	9179	9721	10343
21.5	7704	8650	8298	9287	9829	10463
22	7930	8919	8521	9553	10095	10729
22.5	8038	9027	8629	9661	10212	10837
23	8261	9293	8858	9933	10478	11103
23.5	8369	9401	8966	10041	10586	11223
24	8595	9670	9189	10307	10852	11489
24.5	8703	9778	9297	10415	10969	11597
25	8926	10044	9526	10687	11235	11863
25.5	9034	10152	9634	10795	11343	11983
26	9260	10421	9857	11061	11609	12249
26.5	9368	10529	9965	11169	11726	12357
27	9591	10795	10194	11441	11992	12623
27.5	9699	10903	10302	11549	12100	12743
28	9925	11172	10525	11815	12366	13009

Continues on next page

# 1 Description

## 1.1.2 Technical data

*Continued*

Carriage NO.	1 Carriage		2 Carriages		3 Carriages	4 Carriages
	only internal cable tray (Kg)	only external cable tray (Kg)	only internal cable tray (Kg)	only external cable tray (Kg)	Standard (Kg)	Standard (Kg)
28.5	10033	11280	10633	11923	12483	13117
29	10256	11546	10862	12195	12749	13383
29.5	10364	11654	10970	12303	12857	13503
30	10590	11923	11193	12569	13123	13769
30.5	10698	12031	11301	12677	13240	13877
31	10921	12297	11530	12949	13506	14143
31.5	11029	12405	11638	13057	13614	14263
32	11255	12674	11861	13323	13880	14529
32.5	11363	12782	11969	13431	13997	14637
33	11586	13048	12198	13703	14263	14903
33.5	11694	13156	12306	13811	14371	15023
34	11920	13425	12529	14077	14637	15289
34.5	12028	13533	12637	14185	14754	15397
35	12251	13799	12866	14457	15020	15663
35.5	12359	13907	12974	14565	15128	15783
36	12585	14176	13197	14831	15394	16049
36.5	12693	14284	13305	14939	15511	16157
37	12916	14550	13534	15211	15777	16423
37.5	13024	14658	13642	15319	15885	16543
38	13250	14927	13865	15585	16151	16809
38.5	13358	15035	13973	15693	16268	16917
39	13581	15301	14202	15965	16534	17183
39.5	13689	15409	14310	16073	16642	17303
40	13915	15678	14533	16339	16908	17569



### Note

The weight does not include additional options, tools and other equipment fitted on the robot.

### Transfer load

The following table shows the maximum transfer load of IRT 710.

Load	IRT 710
Max. Transfer Load	3,000 kg

*Continues on next page*

# 1 Description

## 1.1.2 Technical data

Continued



### Note

The payloads listed above are estimated for a wide range of IRT 710 applications. Robot payload is specified in the Product Specification for the robot.

### Airborne noise level

The sound pressure level outside the working space.

IR(B)T type	Level
IRT 710	< 75 dB (A) / 1m

### Power consumption at max load

Type of Movement	IR(B)T
-	Within specification for respective robot. A power consumption measurement of a track motion with manipulator could be done with a simulated cycle in RobotStudio.

### Storage conditions

The table shows the allowed storage conditions for the robot:

Parameter	Value
Minimum ambient temperature	5 °C
Maximum ambient temperature	45 °C
Maximum ambient temperature (less than 24 hrs)	70 °C
Maximum ambient humidity	Maximum 95% at constant temperature.
Maximum ambient altitude	1,000 m

### Operating conditions

The table shows the allowed operating conditions for the robot:

Parameter	Value
Minimum ambient temperature	+5 °C <sup>i</sup> (41 °F)
Maximum ambient temperature	+ 45 °C (113 °F)
Maximum ambient humidity	Maximum 95% at constant temperature.
Maximum ambient altitude	1,000 m

<sup>i</sup> At low environmental temperature < 10° C is, as with any other machine, a warm-up phase recommended to be run with the robot. Otherwise there is a risk that the robot stops or run with lower performance due to temperature dependent oil- and grease viscosity.

1.1.3 Information labels

Illustration

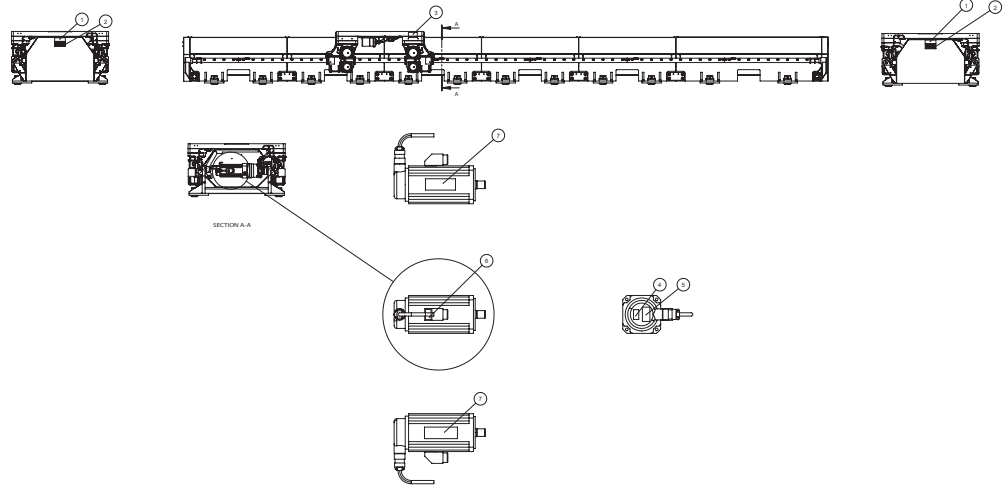

xx220000872

Item	Description
1	ABB Logo
2	Rating Label
3	Lifting Label
4	NO SHOCK Warning Label
5	Instruction Plate
6	Electric shock Warning Label
7	High Temperature Warning Label

# 1 Description

## 1.2.1 Applicable standards

## 1.2 Standards

### 1.2.1 Applicable standards



#### Note

The listed standards are valid at the time of the release of this document. Phased out or replaced standards are removed from the list when needed.

#### General

The product is designed in accordance with ISO 10218-1:2011, Robots for industrial environments - Safety requirements -Part 1 Robots, and applicable parts in the normative references, as referred to from ISO 10218-1:2011. In case of deviations from ISO 10218-1:2011, these are listed in the declaration of incorporation which is part of the product delivery.

#### Normative standards as referred to from ISO 10218-1

Standard	Description
ISO 9283:1998	Manipulating industrial robots - Performance criteria and related test methods
ISO 10218-2	Robots and robotic devices - Safety requirements for industrial robots - Part 2: Robot systems and integration
ISO 12100	Safety of machinery - General principles for design - Risk assessment and risk reduction
ISO 13849-1:2006	Safety of machinery - Safety related parts of control systems - Part 1: General principles for design
ISO 13850	Safety of machinery - Emergency stop - Principles for design
IEC 60204-1	Safety of machinery - Electrical equipment of machines - Part 1: General requirements

#### Other standards used in design

Standard	Description
IEC 61000-6-2	Electromagnetic compatibility (EMC) – Part 6-2: Generic standards – Immunity standard for industrial environments
IEC 61000-6-4	Electromagnetic compatibility (EMC) – Part 6-4: Generic standards – Emission standard for industrial environments
ISO 13732-1:2006	Ergonomics of the thermal environment - Part 1
IEC 60529:1989 + A2:2013	Degrees of protection provided by enclosures (IP code)

### 1.3 Installation

#### 1.3.1 Introduction to installation and commissioning

---

##### General

This chapter contains assembly instructions and information for installing the IRT 710 at the working site.

See also the product manual for the robot controller.

The installation must be done by qualified installation personnel in accordance with the safety requirements set forth in the applicable national and regional standards and regulations.

---

##### Safety information

Before any installation work is commenced, all safety information must be observed.

There are general safety aspects that must be read through, as well as more specific safety information that describes the danger and safety risks when performing the procedures. Read the chapter *Safety* in product manual before performing any installation work.

# 1 Description

## 1.3.2.1 Track motion IRT 710 overview

## 1.3.2 On-site installation

### 1.3.2.1 Track motion IRT 710 overview

#### IRT 710 overview

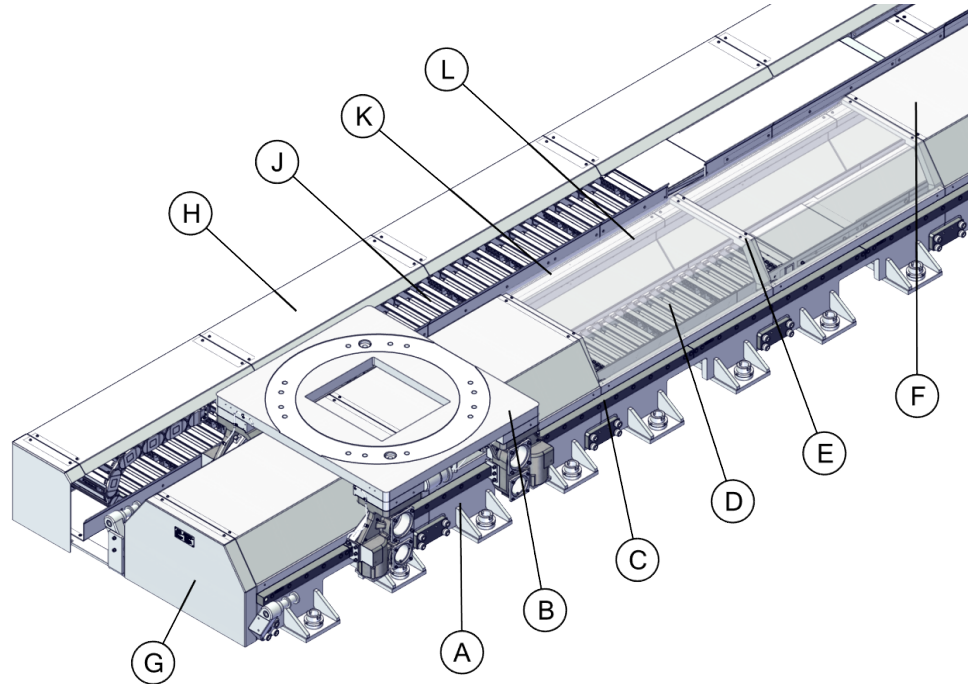

xx2200000409

A	Section
B	Carriage
C	Rectangular Rail
D	Internal cable chain
E	Cover bracket
F	Track cover
G	Terminal cover
H	External cable chain cover
J	External cable chain
K	Rack cover
L	Rack

The same components are used in different layout variants.

*Continues on next page*



### IRT 710 carriage overview

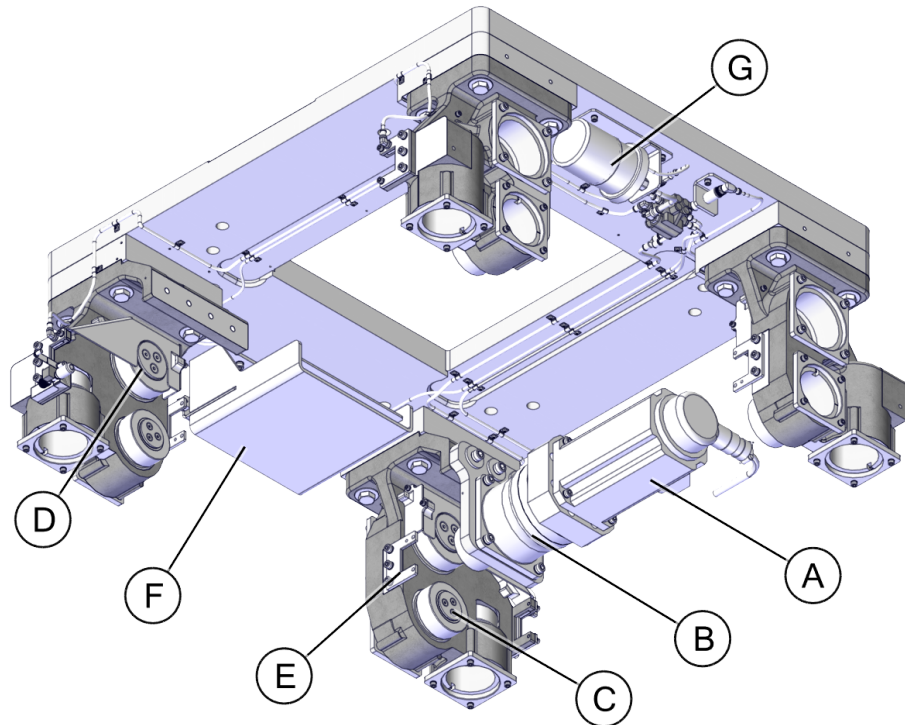

xx2200000410

A	Motor
B	Reducer
C	90 mm Cam roller holder unit
D	110 mm Cam roller holder unit
E	Scraper unit
F	Cable drawer
G	Lubrication system

### Weight, Carriages

Carriage type	Large robot carriage	Medium robot carriage	Transfer carriage
Weight	556 kg	517 kg	537 kg

*Continues on next page*

# 1 Description

## 1.3.2.1 Track motion IRT 710 overview

Continued

Large robot carriage mounting plate , IRB 7600, 760, 6700, 6660, 6650S, 6620, 660, 460

The large robot carriage mounting plate is used for IRB 7600, 760, 6700, 6660, 6650S, 6620, 660 and 460.

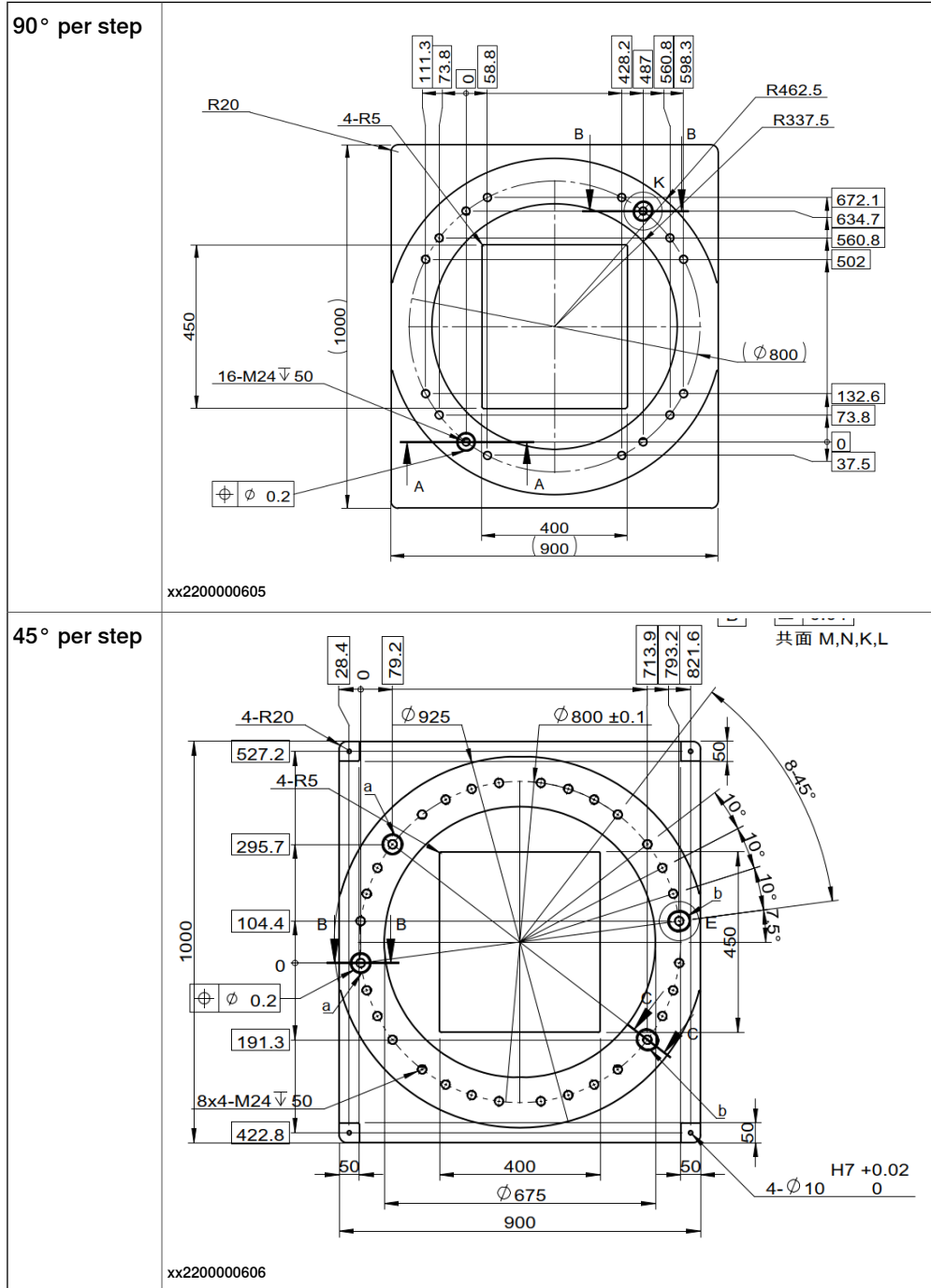

Continues on next page

Medium robot carriage mounting plate, IRB 4600, 4400

The medium robot carriage mounting plate is used for IRB 4600 and 4400.

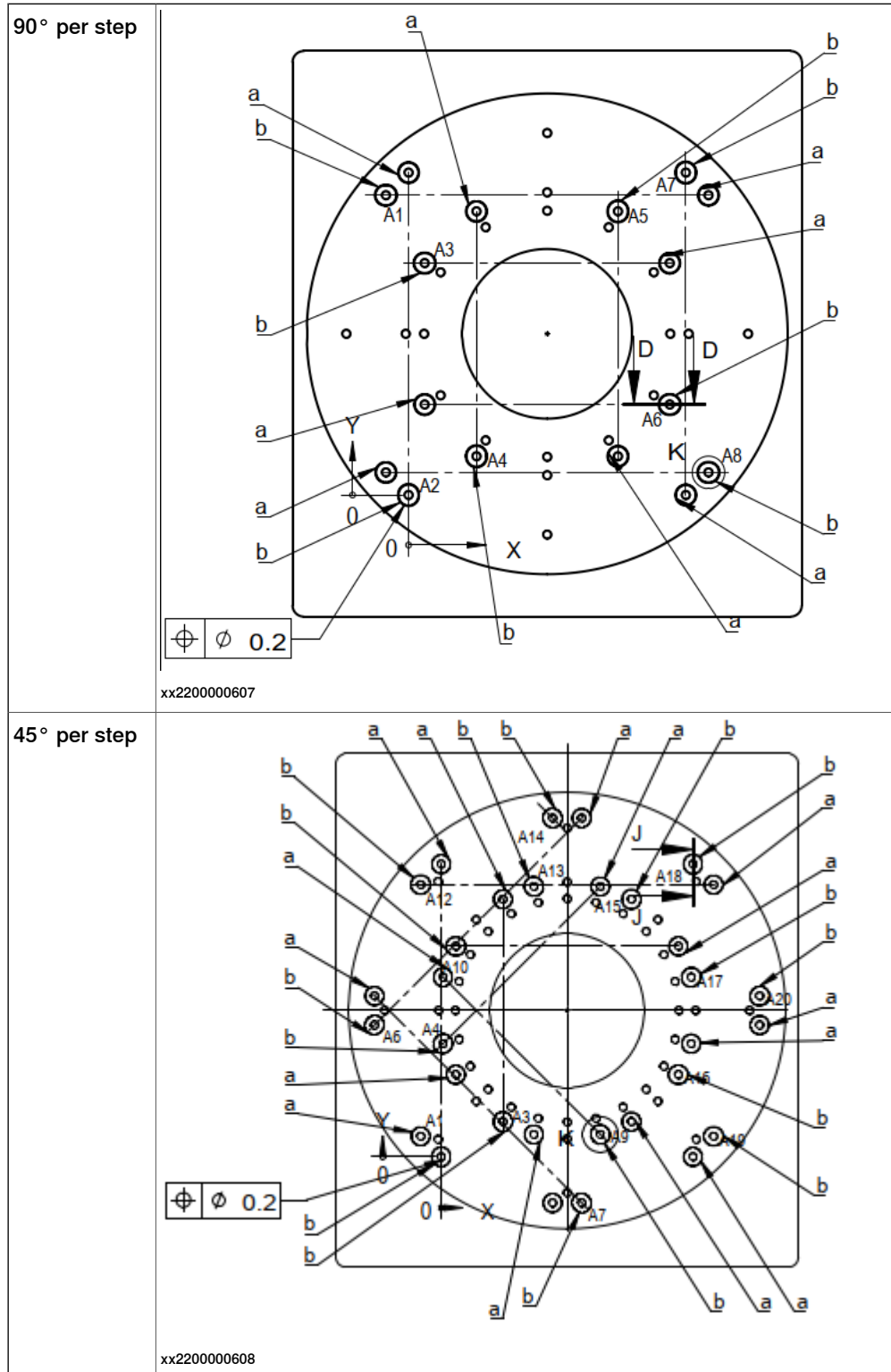

Continues on next page

# 1 Description

## 1.3.2.1 Track motion IRT 710 overview

*Continued*

### Transfer carriage mounting plate

Use the hole configuration when designing fixtures to be used on the transfer carriage. The figure below shows the dimensions in mm.

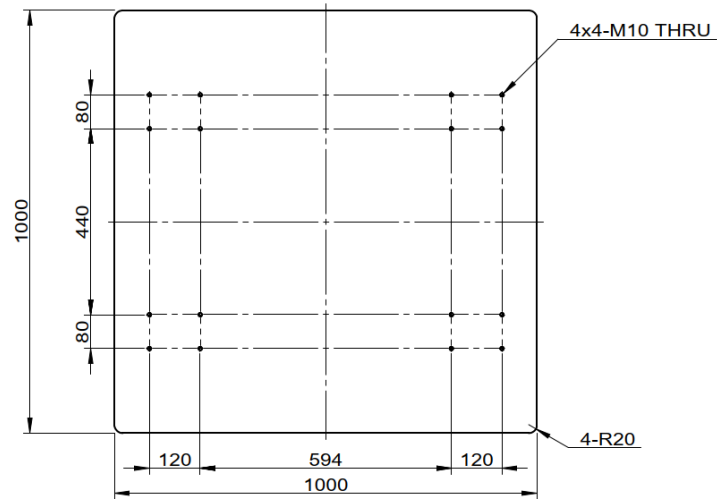

xx220000609

### Easily damaged parts on the track motion

Do not step on the locations marked in the figure since they are easily damaged.

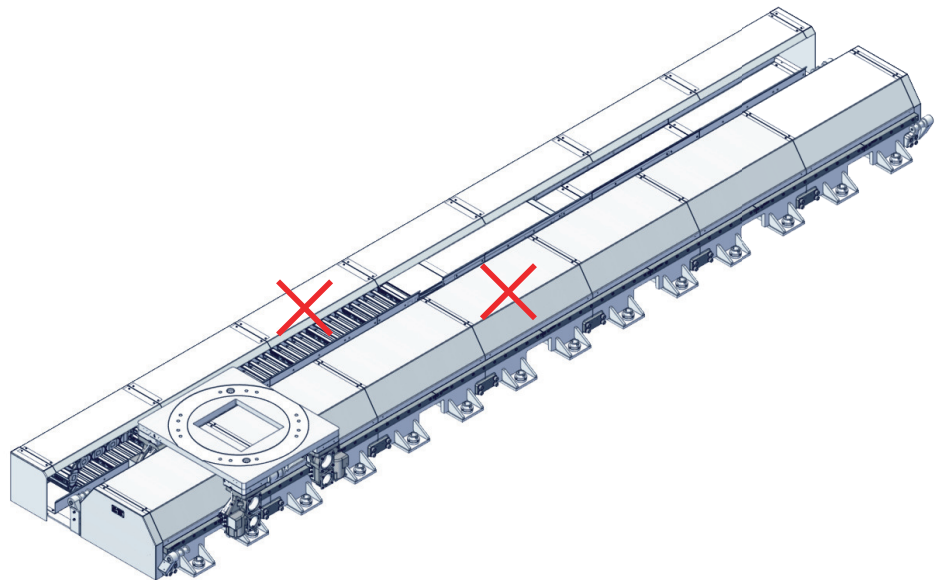

xx220000644

1.3.2.2 Track motion IRT 710 layout

 **Tip**  
The arrow in the illustration refers to the rack side.

One carriage

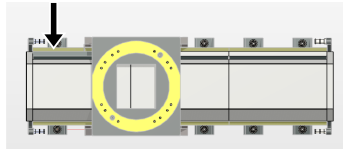

xx2200000610

Two carriages

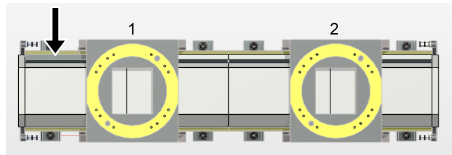

xx2200000611

Three carriages

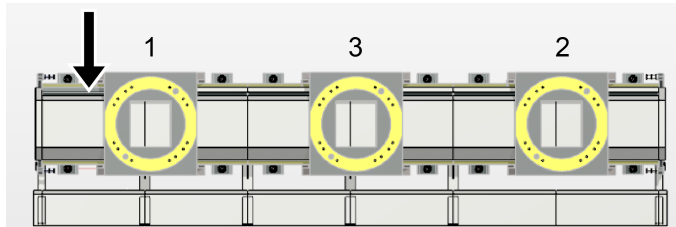

xx2200000612

Four carriages

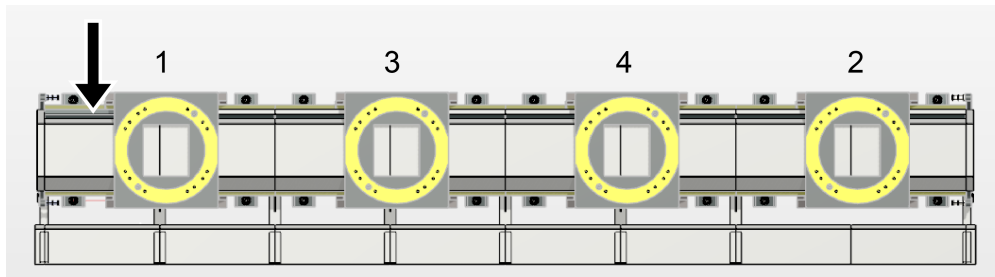

xx2200000613

*Continues on next page*

# 1 Description

## 1.3.2.2 Track motion IRT 710 layout

Continued

### Direction of travel

#### Standard mounting

##### Robot Orientation and Trave direction Robot mounting convention: standard

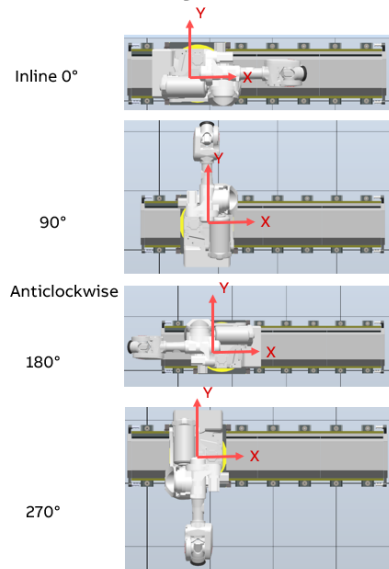

X Travel sense



Y Direction of the frame. Side of Track's which rack installed

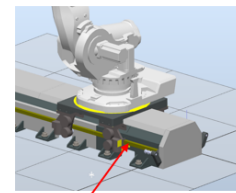
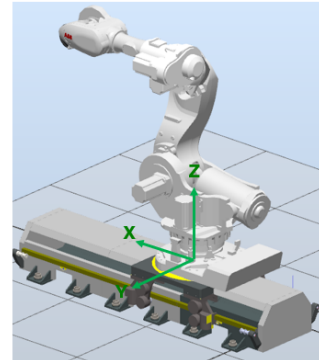

Rack side

xx2200001151

#### Mirrored mounting

##### Robot Orientation and Trave direction Robot mounting convention: Mirrored

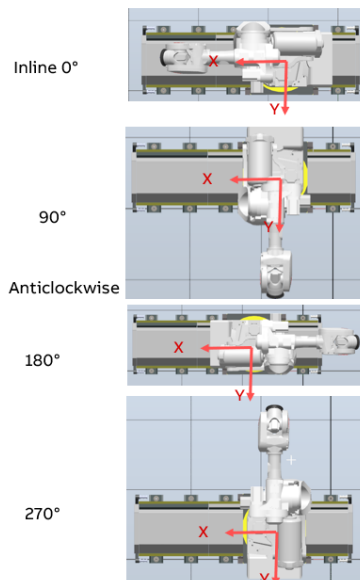

X Travel sense



Y Direction of the frame. Side of Track's which non rack installed

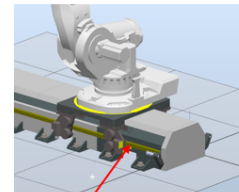
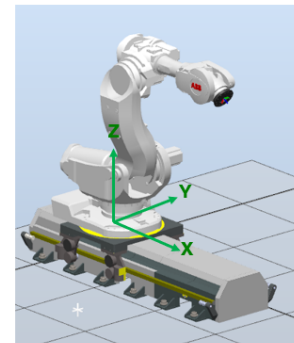

Rack side

xx2200001152

### 1.3.2.3 Foundation

#### Robustness

The foundation must withstand the static loads caused by the weight of the equipment and the dynamic loads generated by the movement of the carriage and the manipulator. The minimum thickness of the concrete floor is 160 mm.

The concrete quality class must be at least C20/25 (or B25) to insure a good resistance of the anchor. Class C30/37 (or B35) is advisable.

The concrete compressive strength can be tested according to the European norm EN 206-1.

When IRT 710 is mounted on the steel platform, M16 class 12.9 screws are required. Depth of thread must be min. 30 mm.

#### Inclination and flatness

The levelling of the track is done by screwing / unscrewing the M60 screws. However, in order to insure a good levelling, the concrete floor inclination must not exceed 1mm / meter in the translation direction, and 0.5mm / meter cross section. The levelling screws can also compensate a poor flatness of the slab and small bumps up to 20 mm. However, the surface under the levelling screw must be flat. A concrete surfacing grinder should be used to correct the flatness locally if necessary.

#### Forces

Maximum floor loads in relation to the base coordination system and indicated per each stand of the section of the track, see figure below.

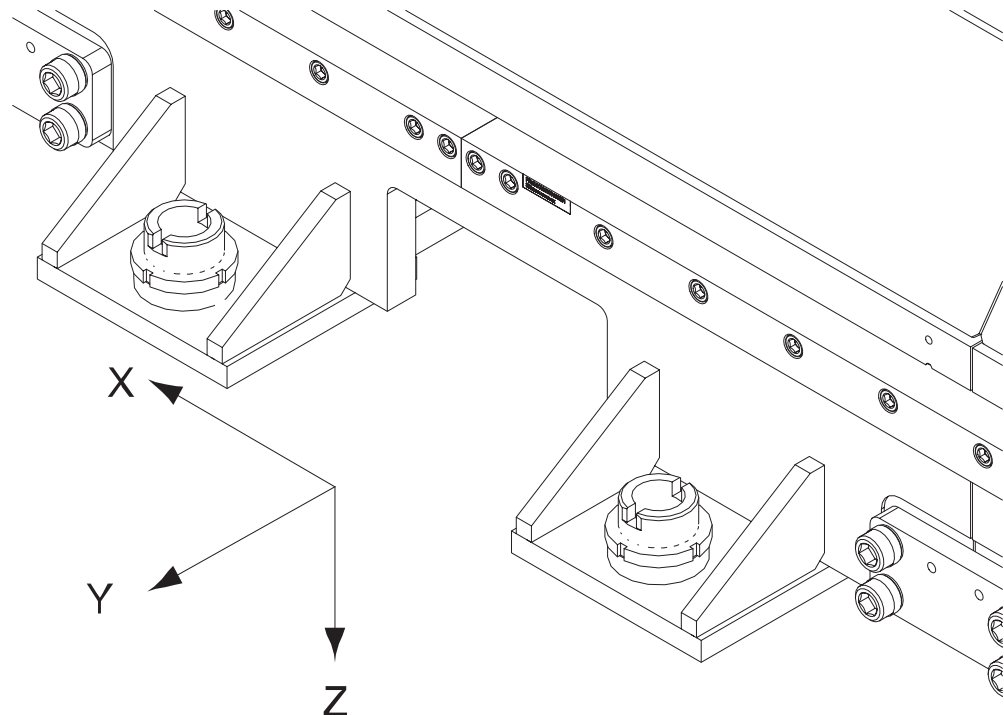

xx2200001254

*Continues on next page*

# 1 Description

## 1.3.2.3 Foundation

Continued

Robot	Max. load at Emergency stop (kN)	
	Fxy	Fz
IRB 7600	+/- 11 KN	-25 KN ~ +40 KN



### Note

If doing fatigue calculations with combined tension (Fz) and shear loads (Fxy), the shear loads (Fxy) are allowed to be reduced with a factor 0.7.

### Floor plate

For these robots application, it is recommended to not put track on ground straightly, put one plate as interface surface to make it more stable. This is not a standard option in list, any request can reach the sales office for help.

The following images show the two types base plate of the IRT 710.

For general condition 1

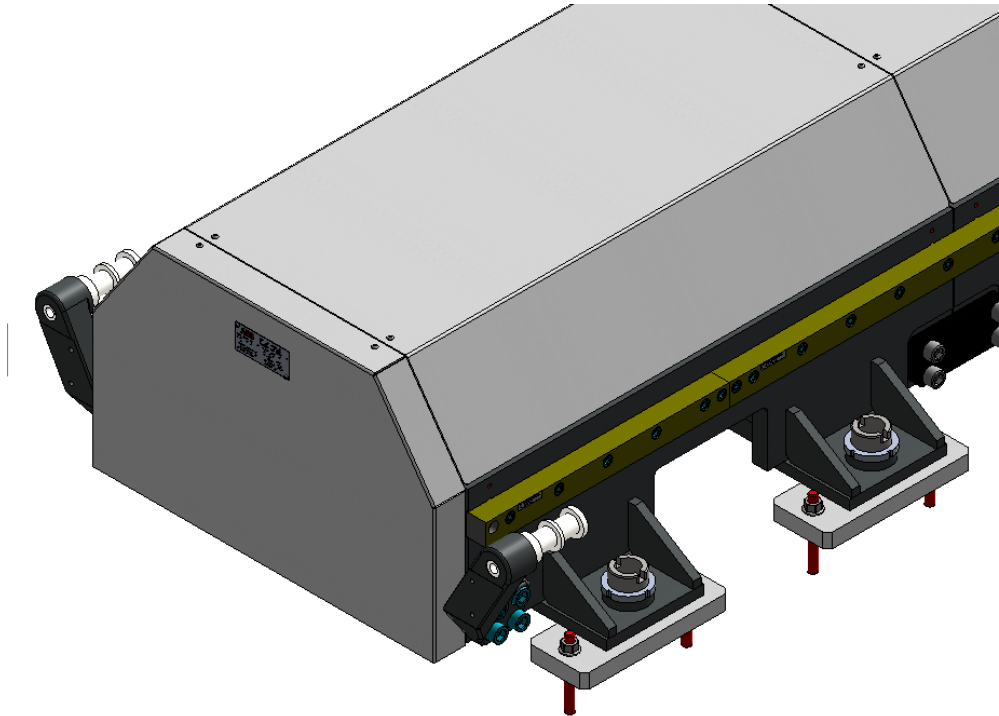

xx2200001199

Continues on next page



# 1 Description

## 1.3.2.3 Foundation Continued

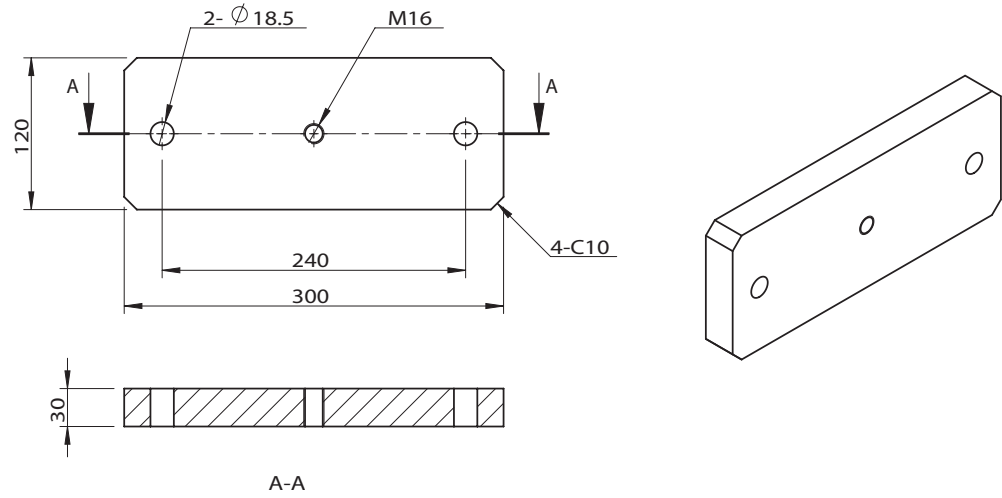

xx2200001282

For general condition 2

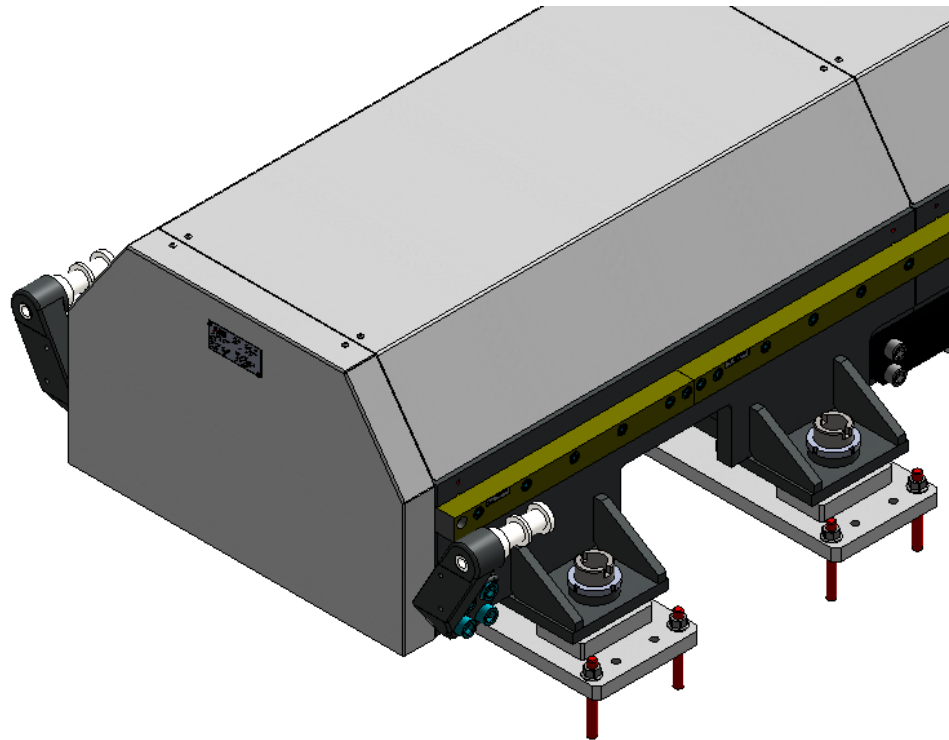

xx2200001200

Continues on next page

# 1 Description

## 1.3.2.3 Foundation

Continued

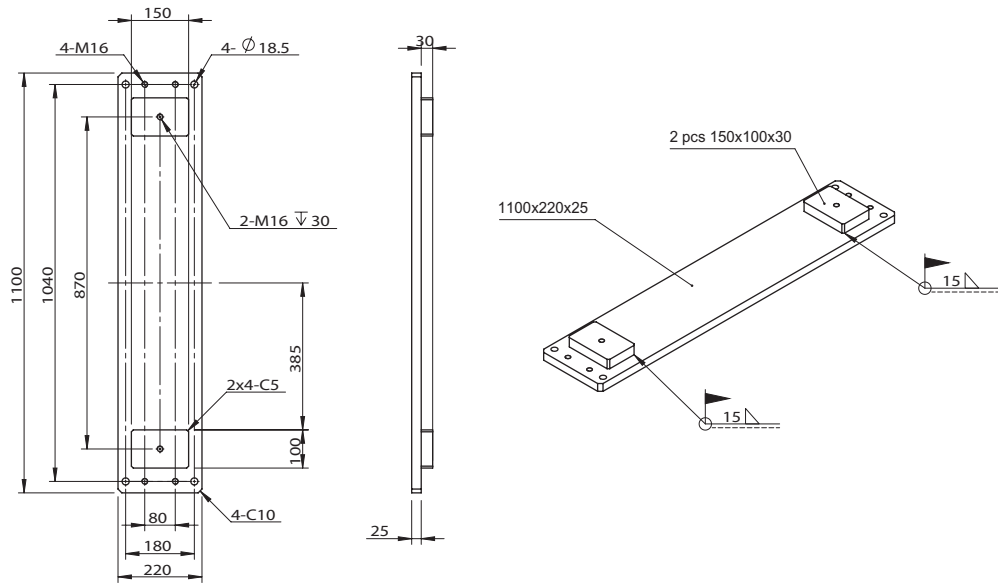

xx2200001283

## Robot capabilities

The following table shows the robot capabilities of the IRT 710.

Standard pedestals are generally allowed between the robot but their height is limited and dependent on the type of robot.

<p>3HKA00000190345</p>	<p>xx2200000661</p>
<p>3HKA00000190346</p>	<p>xx2200000663</p>

Continues on next page

# 1 Description

## 1.3.2.3 Foundation Continued

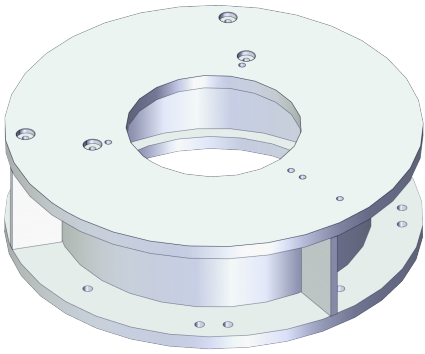
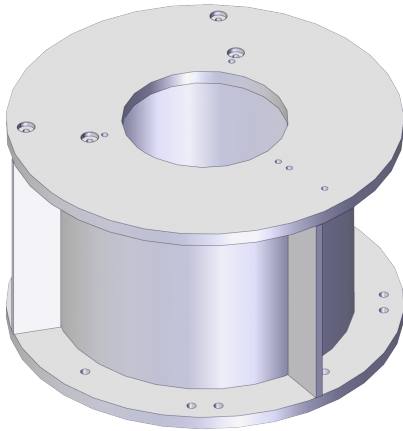
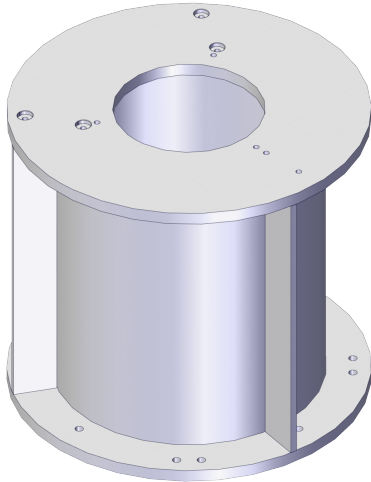
3HKA00000190348	 <p data-bbox="735 629 847 651">xx220000662</p>
3HKA00000190349	 <p data-bbox="735 1106 847 1128">xx220000664</p>
3HKA00000190350	 <p data-bbox="735 1637 847 1659">xx220000665</p>

### Pedestal introduction

Robot Pedestal	Height	Weight	IRB 7600	IRB 760	IRB 6660	IRB 6650S	IRB 6700	IRB 6620	IRB 660	IRB 460	IRB 4400	IRB 4600
3HKA00000190345	250 mm	213 kg	√	√	√	√	√	√	√	√		
3HKA00000190346	500 mm	288 kg					√	√	√	√		

Continues on next page

# 1 Description

---

## 1.3.2.3 Foundation

*Continued*

Robot Pedestal	Height	Weight	IRB 7600	IRB 760	IRB 6660	IRB 6650S	IRB 6700	IRB 6620	IRB 660	IRB 460	IRB 4400	IRB 4600
3HKA00000190348	250 mm	220 kg									√	√
3HKA00000190349	500 mm	276 kg									√	√
3HKA00000190350	750 mm	331 kg										√

### 1.3.2.4 Screw joints

---

#### General

This section details how to tighten the various types of screw joints on the robot and the IRT 710.

The instructions and torque values are valid for screw joints comprised of metallic materials and do not apply to soft or brittle materials.

---

#### Screw class

Class 12.9 screw is recommended by ABB for certain screw joints. These screws are high grade quality and extremely resistant to fatigue. Whenever used, this is specified in the instructions, and in such cases, no other type of replacement screw is allowed! Using other types of screws will void any warranty and may potentially cause serious damage or injury!

---

#### Loctite 243

A thread lock should be used on all screws that have a specified torque and only where stated. This is required to prevent the risk of the screw loosening due to vibrations over the lifetime of the product. Loctite 243 is the recommended thread lock and should be applied to the screws before assembly and tightening to their recommend torque.

# 1 Description

## 1.3.2.5 Assembly of the manipulator

### 1.3.2.5 Assembly of the manipulator

#### Overview

When the IRT 710 is carrying an IRB robot it behaves like an integrated 7th axis. The robot should be ordered with an additional drive unit (907-1) for the IRT 710 motor, and optionally a resolver connection for 7th axis on the robot base (864-1). The IRT 710 unit is designed to be controlled with ABB IRC5 controller. For compatibility with other control systems please contact ABB.

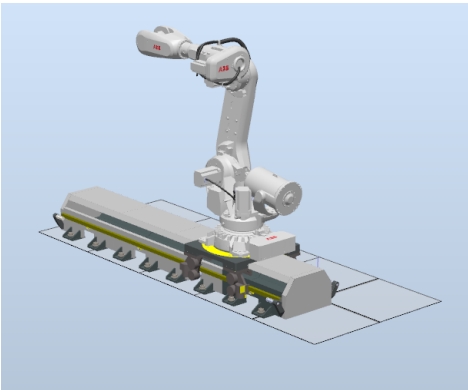
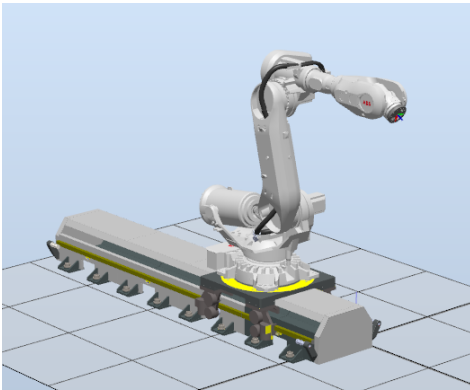
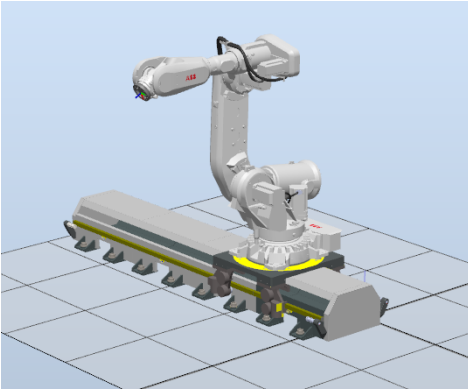
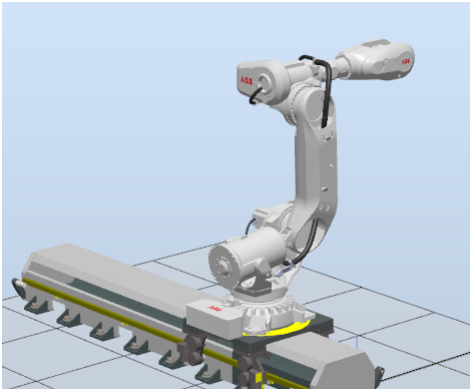
Robot position on the carriage - 4 possibilities:				
Stand- ard <sup>i</sup>	In line with the track, 0°	 xx2200000636	180°	 xx2200000638
	90°	 xx2200000637	270°	 xx2200000639

<sup>i</sup> The illustration described the manipulator installation orientation 0°, 90°, 180° and 270° on robot base and it deduced the manipulator installation orientation 45°, 135°, 225° and 315° from this.

Continues on next page

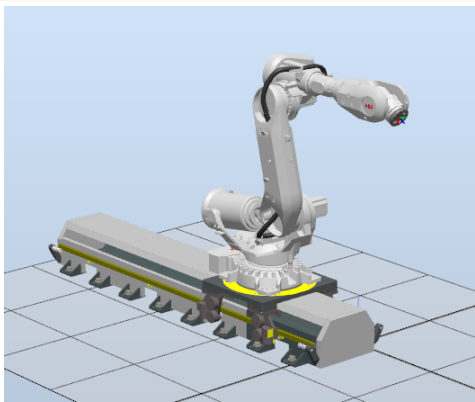
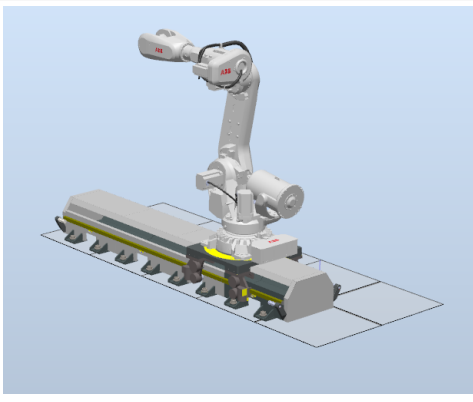
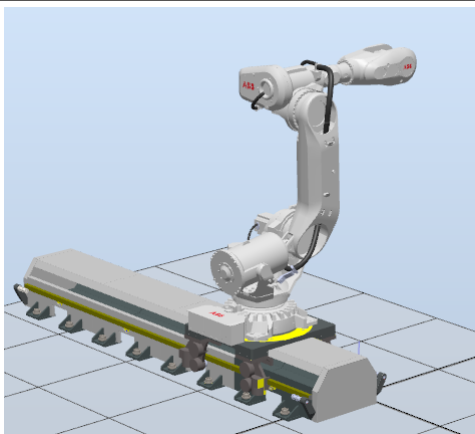
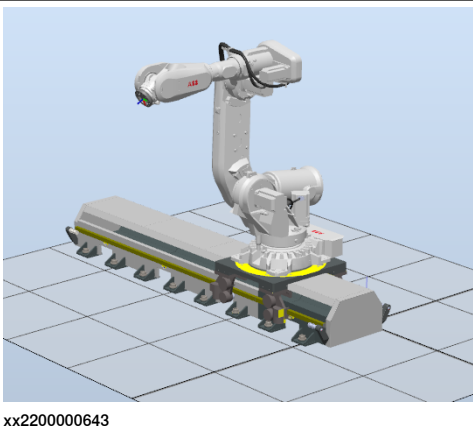
Robot position on the carriage - 4 possibilities:			
Mirrored <sup>i</sup>	In line with the track, 0°	 <p>xx2200000640</p>	<p>180°</p>  <p>xx2200000642</p>
		<p>90°</p>  <p>xx2200000641</p>	<p>270°</p>  <p>xx2200000643</p>

<sup>i</sup> The illustration described the manipulator installation orientation 0°, 90°, 180° and 270° on robot base and it deduced the manipulator installation orientation 45°, 135°, 225° and 315° from this.

# 1 Description

## 1.3.3 Cabling of the IRT 710

### 1.3.3 Cabling of the IRT 710

#### Description

The IRT 710 has an internal cable chain which carries flexible movement cables. The IRT 710 motor can be controlled through an external SMB box, or through the integrated SMB card of a manipulator.

Static cables connect to the IRC5 controller.

#### Schema

The schema below shows the typical control architecture of IRT 710:

#### Track with robot (except IRB 4400)

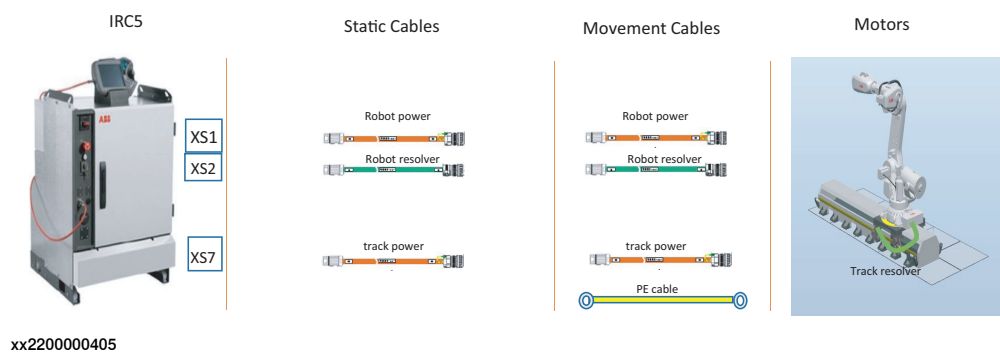

#### Track with IRB 4400

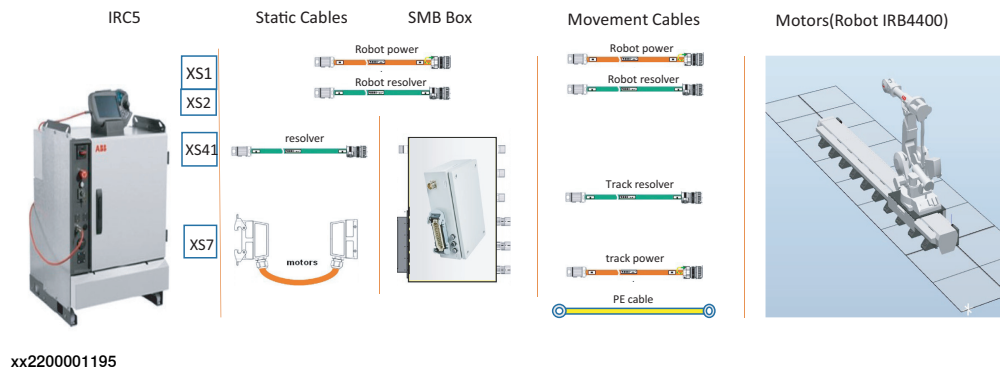

#### Track with Servo gun

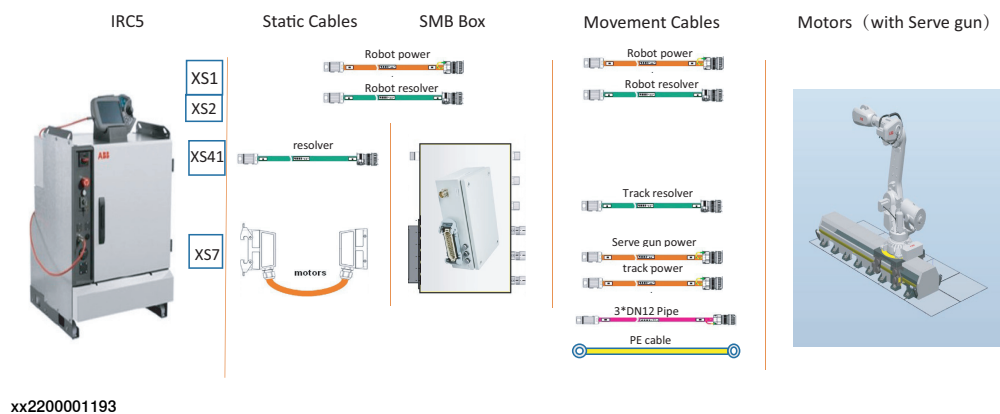

Continues on next page



### Transfer carriage

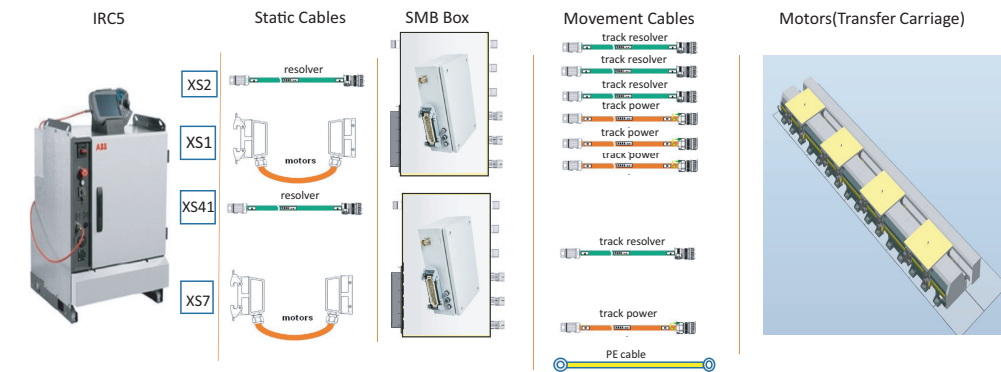

xx2200001194

The flexible movement cables exit the track at the middle of the stroke of the carriage and are selected from standard lengths based on the travel length of the carriage based on the total stroke of the carriage.

### IRT 710 cables lengths

For more details on the cable lengths, see *Spare parts* chapter in product manual.

### Robot cables

If the IRT 710 is ordered prepared for a manipulator, the cable chain should contain the suitable flexible movement cables for the robot. Robot floor cables should be ordered with the robot.



#### Tip

It is important to indicate the robot mounting orientation in the order form in order to get the correct robot cable length.

# 1 Description

---

## 1.3.4 Specifications of the movement cables

### 1.3.4 Specifications of the movement cables

---

#### **Movement cables diameter and weight**

The internal cable chain usually contains the IRT 710 motor power and resolver cables. When additional cables are used, it is important to ensure that they can all fit in. In particular, if a number  $n$  of cables are used, you must make sure that:

- The total width of all the cables added together, as well as the width of  $n-1$  separators (5 mm each), does not exceed the internal width of the cable chain (250 mm).
- The total weight of all cables does not exceed 6.5 kg/m.

1.3.5 Connectors on IRC5 controller

General

The following section describes the connectors on the front panel of the IRC5 controller.



**CAUTION**

Always inspect the connector for dirt or damage before connecting it to the controller. Clean or replace any damaged parts.



**Note**

It is important that the earth connection point (B) is connected to a ground plane, in order to avoid disturbance.

Connectors

The following details the connection interface on the IRC5 controller. See also the circuit diagram, *Circuit diagram - IRC5*.

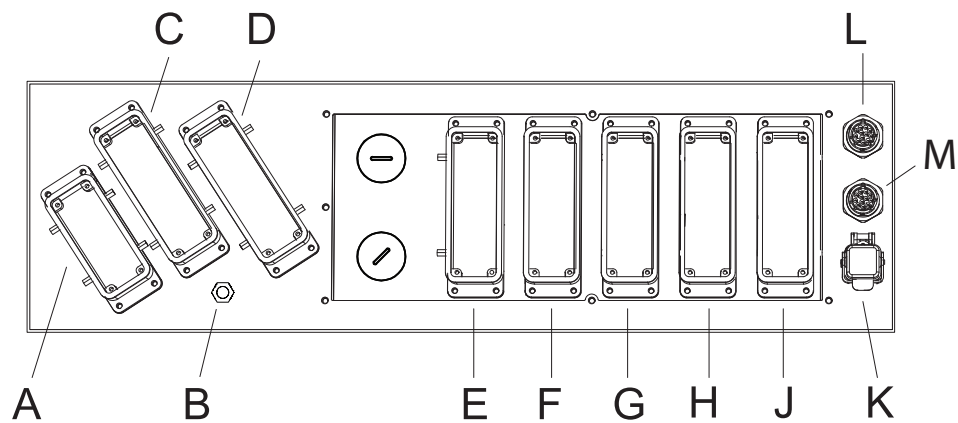

xx0500001852

	Description	Reference on the circuit diagram
A	Mains connection	XP.0
B	Earth connection point	
C	Robot power connection	XS.1
D	Additional axes power connection	XS.7
E	Customer power/signals external connection	XS.13/XS.5
F	Customer options	XS.10
G	Customer options	XS.11
H	Customer options	XS.12
J	Customer safety signals	X3
K	Network connection	XP.28

*Continues on next page*

# 1 Description

---

## 1.3.5 Connectors on IRC5 controller

*Continued*

	Description	Reference on the circuit diagram
L	Additional axes SMB connection	XS.41
M	Robot SMB connection	XS.2

1.3.6 Connectors on Drive Module

General

The following section describes the connectors on the Drive Module. The Drive Module is detailed in section Installation of additional Drive Module in *Product manual - IRC5*.

Connections

The following details the connectors on the front panel of the Drive Module.

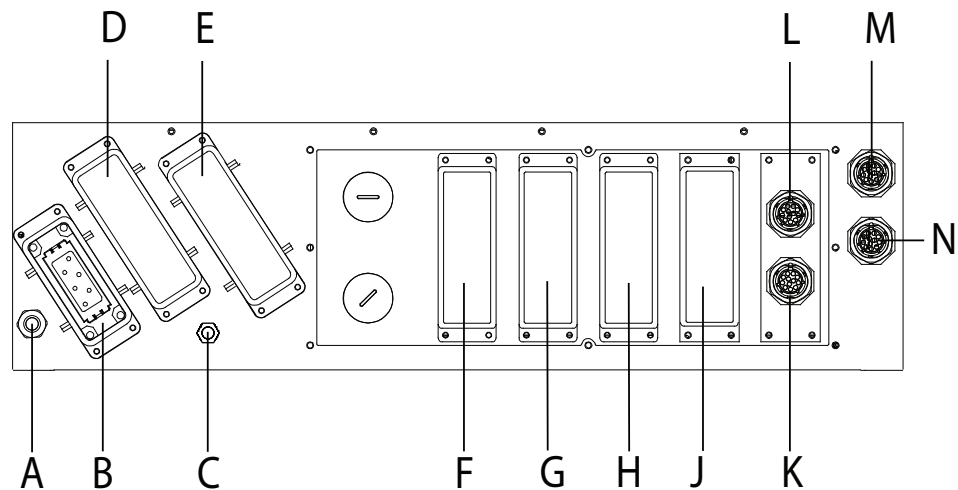

xx0600002931

	Description
A	Power connection to Control Module
B	A4.X0: Mains connection to transformer
C	Earth connection point
D	A4.X1: Robot power connection
E	A4.X7: External axes power connection
F	A4.XX: Customer options
G	A4.XX: Customer options
H	A4.XX: Customer options
J	A4.XX: Customer options
K	Communication cabling between Control/Drive Module
L	Communication cabling between Control/Drive Module
M	A4.XS41: Additional axes SMB connection
N	A4.XS2: Robot SMB connection

# 1 Description

## 1.3.7 Assembly the cable of the additional axes SMB

### 1.3.7 Assembly the cable of the additional axes SMB

#### Overview

The following section describes the assembly of the additional axes SMB connection on IRC5 controller front panels.



#### Tip

The additional axes SMB is needed for IRB 4400 or spot welding applications.



#### WARNING

Disconnect all electrical supply before installation of the cable.

#### Location of the cable

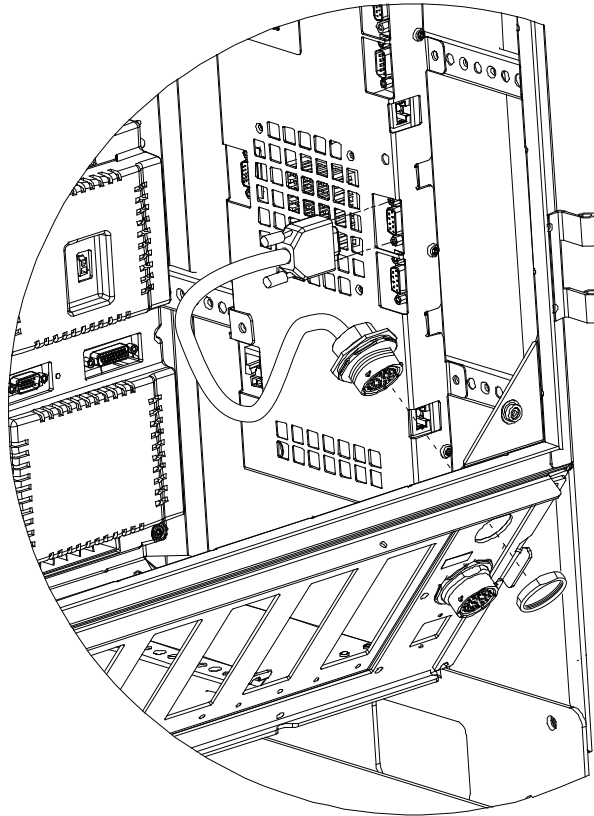

xx1100000710

#### Connecting the cable

	Action	Note
1	Connect the cable harness MS2 XS41 to the connector A42.X5.	

### 1.3.8 Grounding point

#### Grounding and bonding point on track motion

There is a grounding/bonding point on the track motion. The grounding/bonding point is used for potential equalizing between control cabinet, track motion and any peripheral devices.

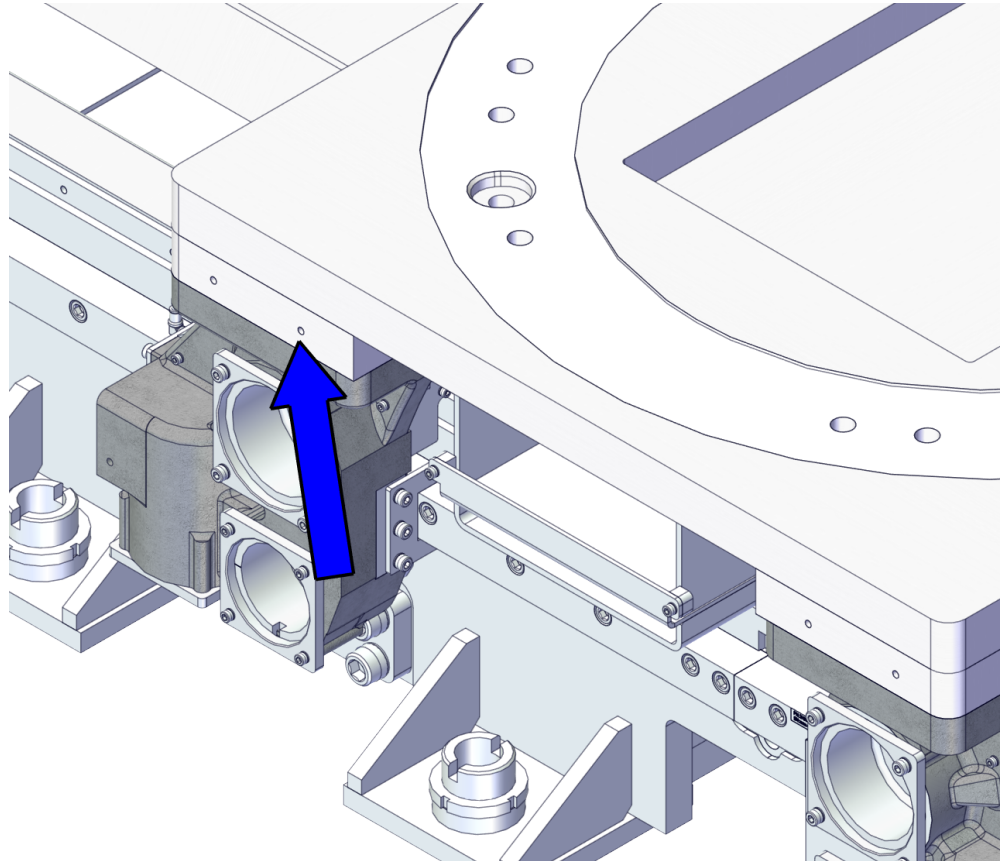

xx220000678

*Continues on next page*

# 1 Description

---

## 1.3.8 Grounding point

*Continued*

### Grounding point for track motion stand

There is also a grounding/bonding point for the track motion stand, located at the mechanical stop.

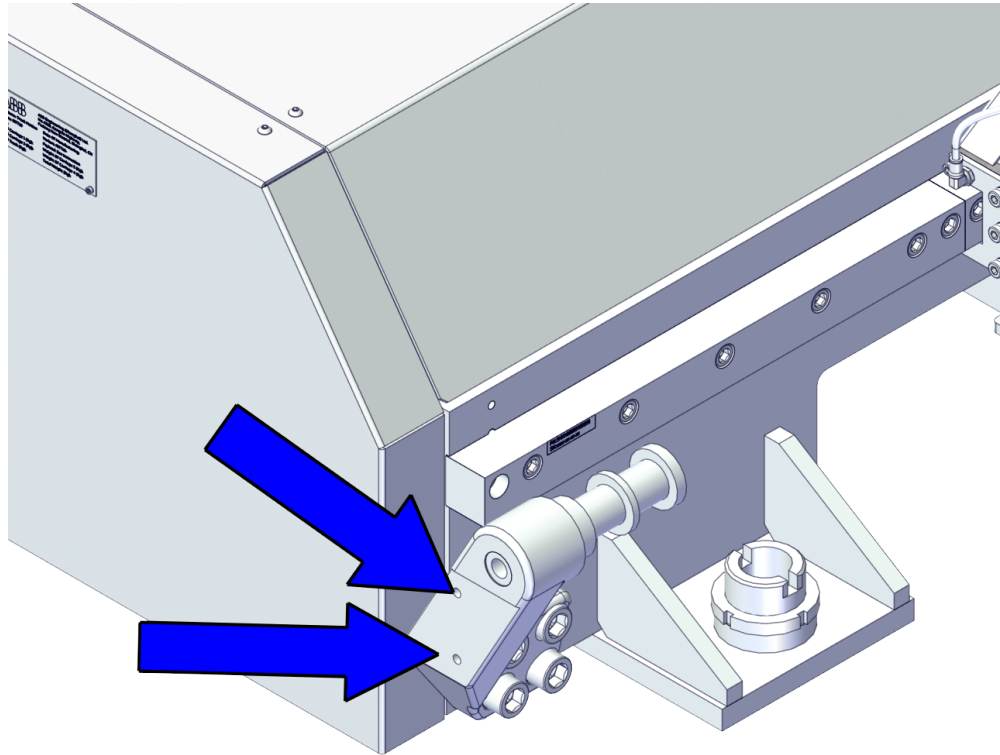

xx2200001186



1.3.9 Lubrication

1.3.9.1 Activating the automatic lubrication system

There are two types of automatic lubrication system can be used in IRT 710. One is HPS, and the other is EPS.

	HPS	EPS
Power supply	4.5 battery	External 24 power
Control method	After setting the use period, install the time loop grease pump to work once, and then work independently according to the set use period until the grease bag is used up.	<p>A The same as the HPS time setting, except that the battery power supply is changed to an external power supply; but the grease pump works once when it is powered on, and then works according to the previously set time period under the condition of uninterrupted power, so it can be synchronized with the equipment (in shutdown or the grease pump does not work during maintenance)</p> <p>B The working frequency of the oil pump is controlled by the equipment PLC. Because the grease pump works once when it is powered on, the customer can control the working frequency of the oil pump by controlling the power on and off frequency of the grease pump with the PLC.</p>

# 1 Description

## 1.3.9.2 Lubrication feedback (optional)

### 1.3.9.2 Lubrication feedback (optional)

#### Overview

To check if the lubrication system works well, it is viable to take use of lubrication feedback system with IRT 710.

The lubrication feedback function can be used with PLC or IRC5.

#### Content

The principle of Switch detection of lubrication:

- 1 After the lubrication feedback system is activated, it will start timing and read the recorded feedback value.
- 2 The value is read every 24 hours and compared to the recorded value.
- 3 If there is no change, the timing continues.
- 4 If there is a change, restart the timing and record the current feedback value.
- 5 If the feedback value has not changed after 5 days, it indicates that the lubrication is abnormal. Please check the lubrication system and grease bag.

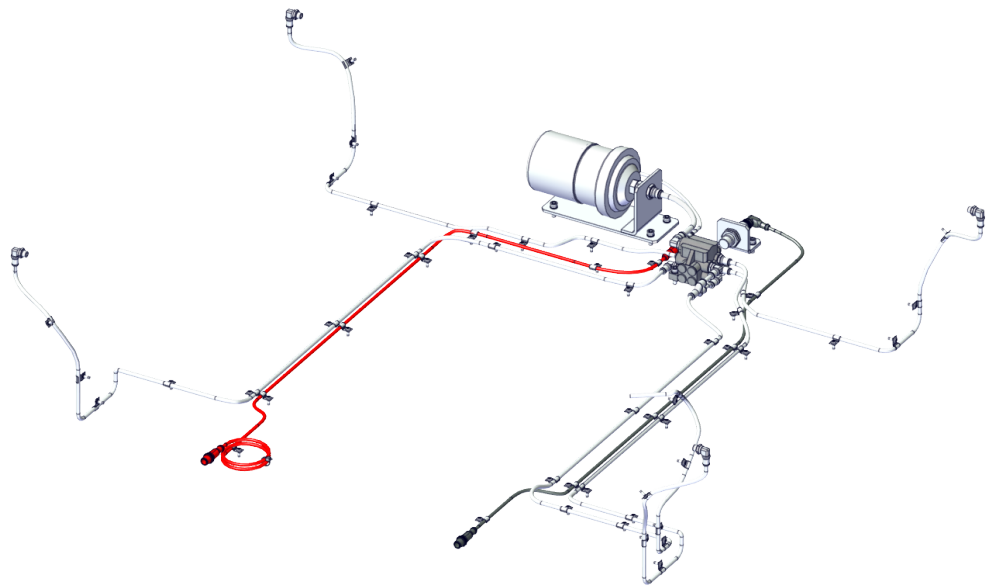

xx2200000795

A	M12 Cable, 1,000 mm (Silver white)
B	Sensor

## 1.4 Calibration

### 1.4.1 Introduction to calibration

#### 1.4.1.1 Introduction and calibration terminology

##### Calibration information

This chapter includes general information about the recommended calibration methods and also the detailed procedures for updating the revolution counters, checking the calibration position etc.

Detailed instructions of how to perform Axis Calibration are given on the FlexPendant during the calibration procedure. To prepare calibration with Axis Calibration method, see [Calibrating with Axis Calibration method on page 54](#).

##### Calibration terminology

Term	Definition
Calibration method	A collective term for several methods that might be available for calibrating the ABB robot. Each method contains calibration routines.
Synchronization position	Known position of the complete robot where the angle of each axis can be checked against visual synchronization marks.
Calibration position	Known position of the complete robot that is used for calibration of the robot.
Standard calibration	A generic term for all calibration methods that aim to move the robot to calibration position.
Fine calibration	A calibration routine that generates a new zero position of the robot.
Reference calibration	<p>A calibration routine that in the first step generates a reference to current zero position of the robot. The same calibration routine can later on be used to recalibrate the robot back to the same position as when the reference was stored.</p> <p>This routine is more flexible compared to fine calibration and is used when tools and process equipment are installed.</p> <p>Requires that a reference is created before being used for recalibrating the robot.</p> <p>Requires that the robot is dressed with the same tools and process equipment during calibration as during creation of the reference values.</p>
Update revolution counter	A calibration routine to make a rough calibration of each manipulator axis.
Synchronization mark	Visual marks on the robot axes. When marks are aligned, the robot is in synchronization position.

# 1 Description

---

## 1.4.1.2 Calibration methods

### 1.4.1.2 Calibration methods

---

#### Overview

This section specifies the different types of calibration and the calibration methods that are supplied by ABB.

---

#### Types of calibration

Type of calibration	Description	Calibration method
Standard calibration	The calibrated robot is positioned at calibration position.	Axis Calibration Pin Calibration

---

#### Brief description of calibration methods

##### Axis Calibration method

Axis Calibration is a standard calibration method for calibration of IRT 710. It is the recommended method in order to achieve proper performance.

The following routines are available for the Axis Calibration method:

- Fine calibration
- Update revolution counters
- Reference calibration

The calibration equipment for Axis Calibration is delivered as a toolkit.

The actual instructions of how to perform the calibration procedure and what to do at each step is given on the FlexPendant. You will be guided through the calibration procedure, step by step.

##### Pin calibration method

With the manual calibration method, the product's axes are positioned in specific calibration positions using calibration tools. Under this condition, the position of the axis to be calibrated is pre-determined. The axes must be calibrated one at a time.

### 1.4.1.3 When to calibrate

---

#### When to calibrate

The system must be calibrated if any of the following situations occur.

#### The resolver values are changed

If resolver values are changed, the track motion must be recalibrated using the calibration methods supplied by ABB. Calibrate the track motion carefully with standard calibration.

The resolver values will change when parts affecting the calibration position are replaced on the track motion, for example motors or parts of the transmission.

This is detailed in [Pin calibration on page 60](#).

#### The revolution counter memory is lost

If the revolution counter memory is lost, the counters must be updated.

- The battery is discharged
- A resolver error occurs
- The signal between a resolver and measurement board is interrupted
- A robot axis is moved with the control system disconnected

The revolution counters must also be updated after the robot and controller are connected at the first installation.

#### The track motion is rebuilt

If the track is rebuilt, for example after a crash or when the reach ability of the track is changed, it needs to be recalibrated for new resolver values.

This is detailed in [Pin calibration on page 60](#).

# 1 Description

---

## 1.4.2.1 Synchronization marks and synchronization position for track motions

## 1.4.2 Synchronization marks and track motion movement directions

### 1.4.2.1 Synchronization marks and synchronization position for track motions

---

#### Introduction

This section shows the position of the synchronization marks and the synchronization position for each carriage.

---

#### synchronization marks - Axis calibration

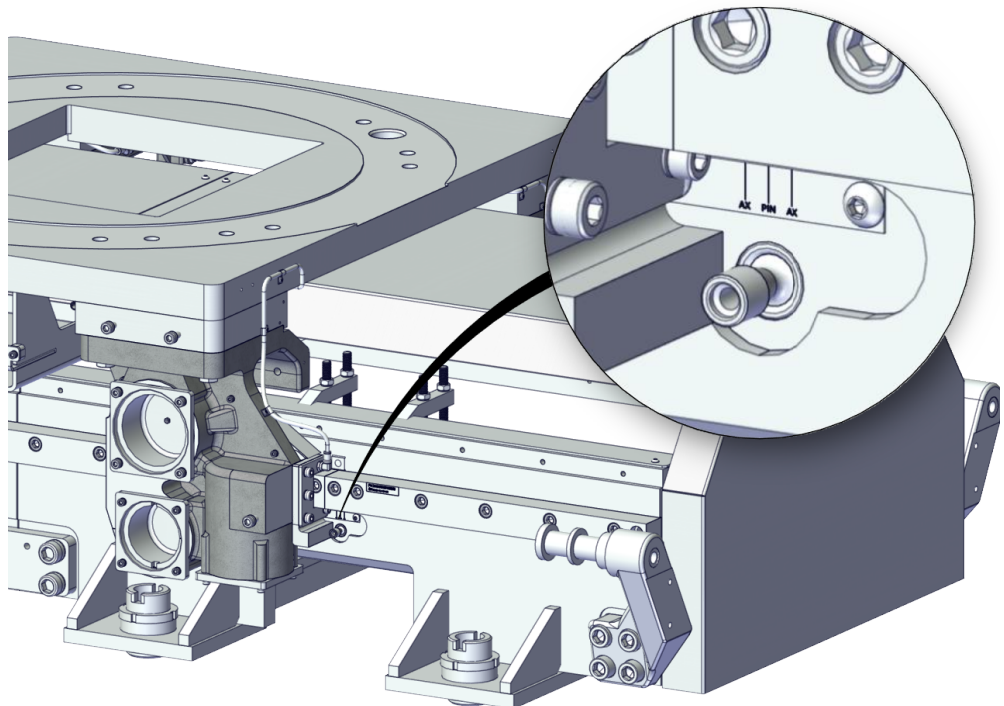

xx2200001157

*Continues on next page*

synchronization marks - Pin calibration

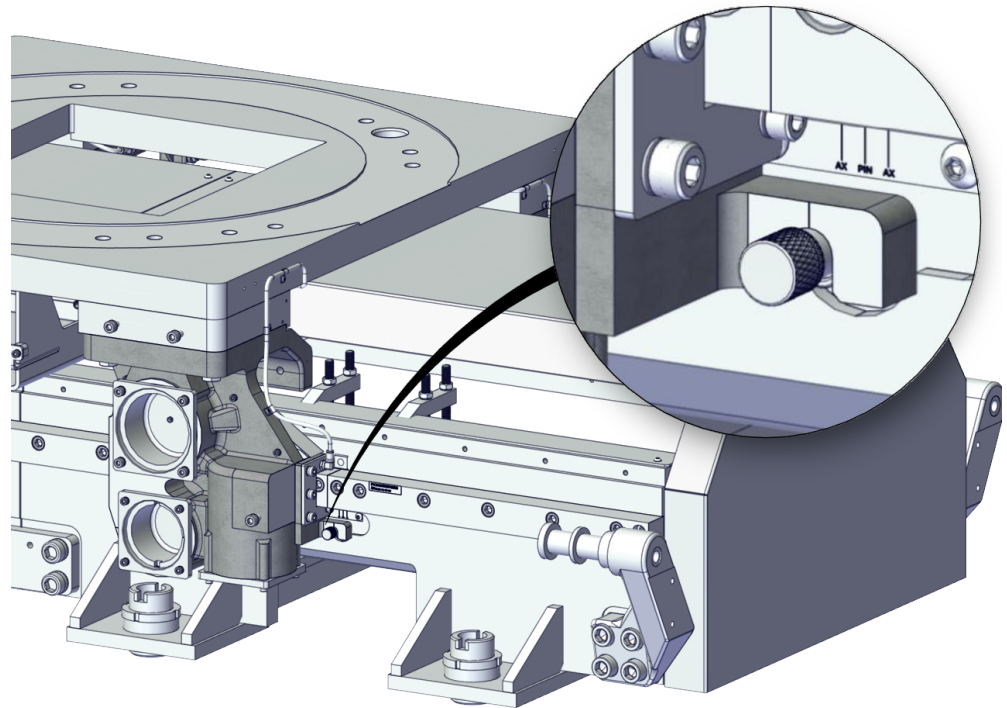

xx2200001158

Synchronization position and movement directions - One carriage

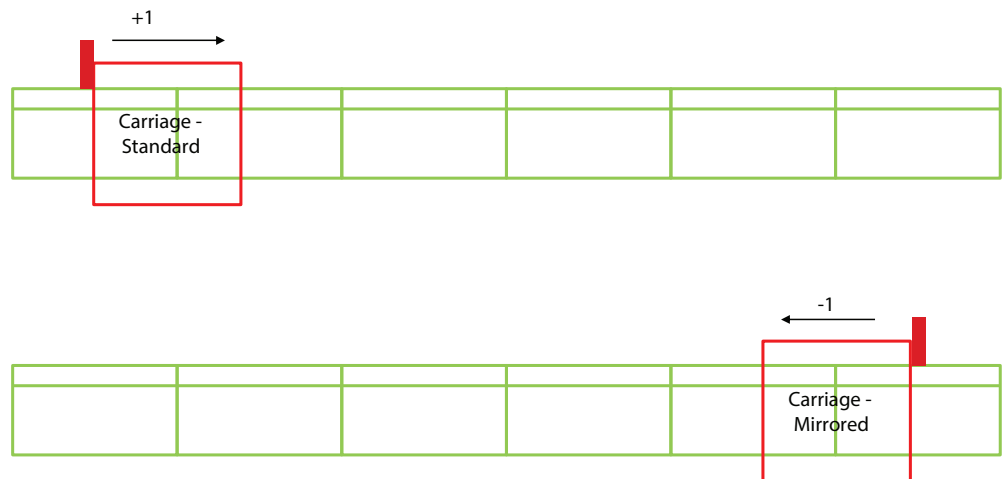

xx2200000394

Continues on next page

# 1 Description

## 1.4.2.1 Synchronization marks and synchronization position for track motions

Continued

### Synchronization position and movement directions - Two carriages

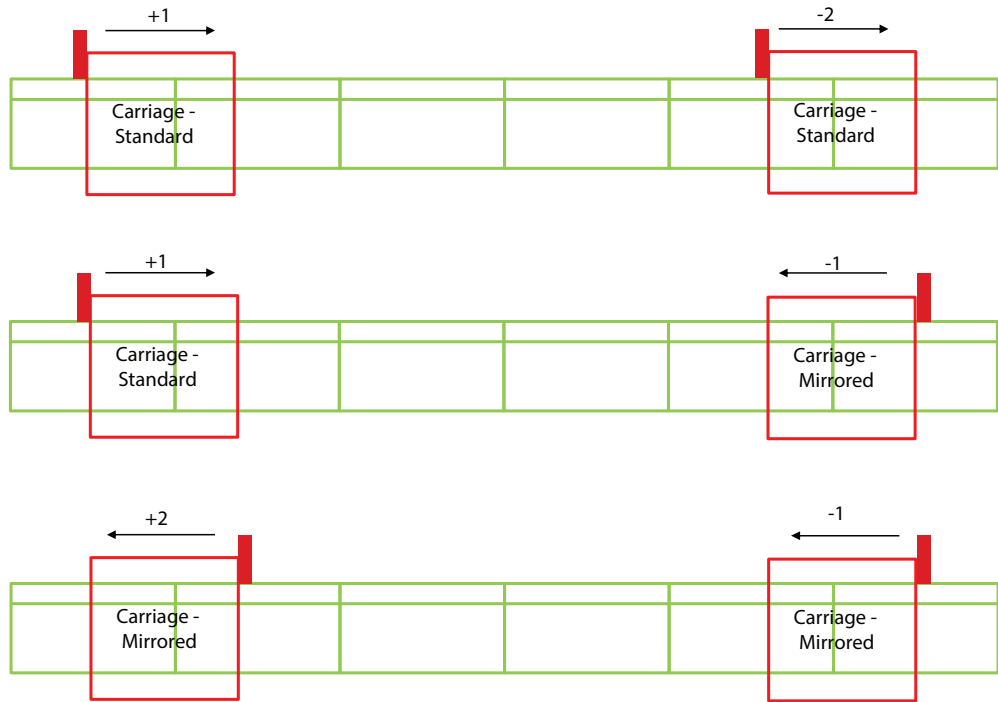

xx2200000395

### Synchronization position and movement directions - Three carriages

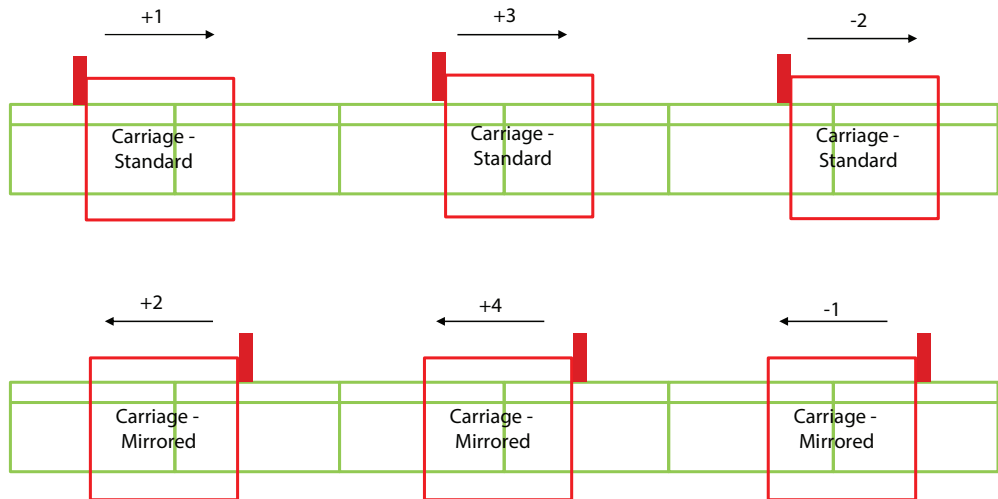

xx2200000396

Continues on next page



1.4.2.1 Synchronization marks and synchronization position for track motions

*Continued*

Synchronization position and movement directions - Four carriages

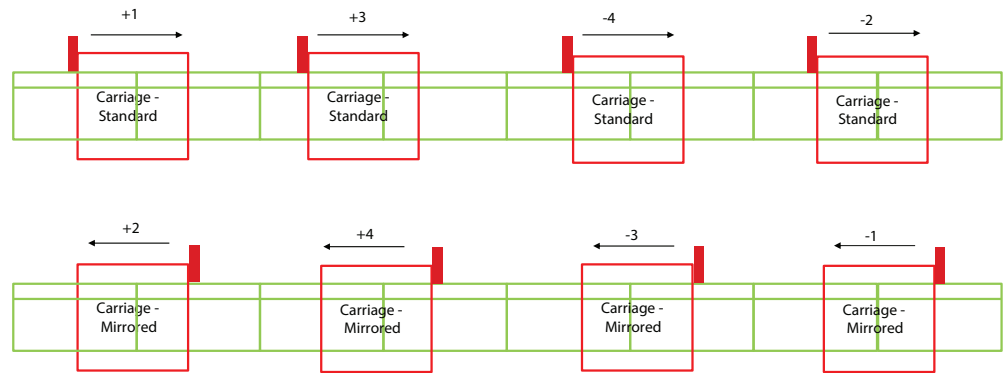

xx220000397

# 1 Description

---

## 1.4.3 Calibrating with Axis Calibration method

### 1.4.3 Calibrating with Axis Calibration method



#### Note

Make sure that the poses of the robots and work objects are always the same before calibration.

*Continues on next page*

### 1.4.3.1 Description of Axis Calibration

#### Instructions for Axis Calibration procedure given on the FlexPendant

The actual instructions of how to perform the calibration procedure and what to do at each step is given on the FlexPendant. You will be guided through the calibration procedure, step by step.

This manual contains a brief description of the method, additional information to the information given on the FlexPendant, article number for the tools and images of where to fit the calibration tools on the robot.

#### Overview of the Axis Calibration procedure

The Axis Calibration procedure applies to all axes, and is performed on one carriage at the time. The carriages are both manually and automatically moved into position, as instructed on the FlexPendant.

Bushings are installed on each calibration position at delivery, for installation of the calibration tools.

The Axis Calibration procedure described roughly:

- 1 A removable calibration tool is inserted by the operator into a calibration bushing on the axis chosen for calibration, according to instructions on the FlexPendant.

**WARNING**

Calibrating the track with Axis Calibration requires special calibration tools from ABB. Using other pins in the calibration bushings may cause severe damage to the robot and/or personnel.

**WARNING**

The calibration tool must be fully inserted into the calibration bushing, until the steel spring ring snaps into place.

- 2 During the calibration procedure, RobotWare moves the carriage chosen for calibration so that the calibration tools get into contact. RobotWare records values of the calibration position and repeats the coming-in-contact procedure several times to get an exact value of the axis position.

**WARNING**

Risk of pinching! The contact force for large robots can be up to 150 kg. Keep a safe distance to the robot.

- 3 The axis position is stored in RobotWare with an active choice from the operator.

*Continues on next page*

# 1 Description

---

## 1.4.3.1 Description of Axis Calibration

*Continued*

---

### Routines in the calibration procedure

The following routines are available in the Axis Calibration procedure, given at the beginning of the procedure on the FlexPendant.

#### Fine calibration routine

Choose this routine to calibrate the track when there are no tools, process cabling or equipment fitted to the track.

#### Reference calibration routine

Choose this routine to create reference values and to calibrate the robot when the robot is dressed with tools, process cabling or other equipment.



#### Note

When calibrating the robot with the reference calibration routine, the robot must be dressed with the same tools, process cabling and any other equipment as when the reference values were created.

If calibrating the robot with reference calibration there must be reference values created before repair is made to the robot, if values are not already available. Creating new values requires possibility to move the robot. The reference values contain positions of all axes, torque of axes and technical data about the tool installed. A benefit with reference calibration is that the current state of the robot is stored and not the state when the robot left the ABB factory. The reference value will be named according to tool name, date etc.

Follow the instructions given in the reference calibration routine on the FlexPendant to create reference values.

When reference calibration is performed, the robot is restored to the status given by the reference values.

#### Update revolution counters

Choose this routine to make a rough calibration of each track carriage by updating the revolution counter for each carriage, using the FlexPendant.

#### Validation

In the mentioned routines, it is also possible to validate the calibration data.

### 1.4.3.2 Calibration tools for Axis Calibration

#### Calibration tool set

The calibration tools used for Axis Calibration are designed to meet requirements for calibration performance, durability and safety in case of accidental damage.

The calibration tool will eventually break from fatigue after longer period of use and then needs to be replaced. There is no risk for bad calibrations as long as the calibration tool is in one piece.



**WARNING**

Calibrating the track with Axis Calibration requires special calibration tools from ABB. Using other pins in the calibration bushings may cause severe damage to the robot and/or personnel.

Equipment, etc.	Article number	Note
Calibration toolbox, Axis Calibration	3HAC055412-001	Delivered as a set of calibration tools. Required if Axis Calibration is the valid calibration method for the robot.

#### Examining the calibration tool

##### Check prior to usage

Before using the calibration tool, make sure that the tube insert, the plastic protection and the steel spring ring are present.



**WARNING**

If any part is missing or damaged, the tool must be replaced immediately.

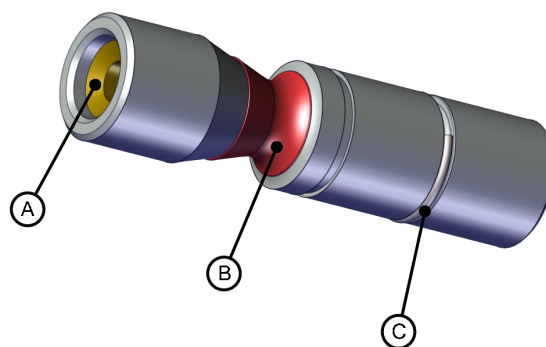

xx1500001914

A	Tube insert
B	Plastic protection
C	Steel spring ring

*Continues on next page*

# 1 Description

---

## 1.4.3.2 Calibration tools for Axis Calibration

*Continued*

### Periodic check of the calibration tool

If including the calibration tool in a local periodic check system, the following measures should be checked.

- Outer diameter within  $\varnothing 12g4$  mm,  $\varnothing 8g4$  mm or  $\varnothing 6g5$  mm (depending on calibration tool size).
- Straightness within 0.005 mm.

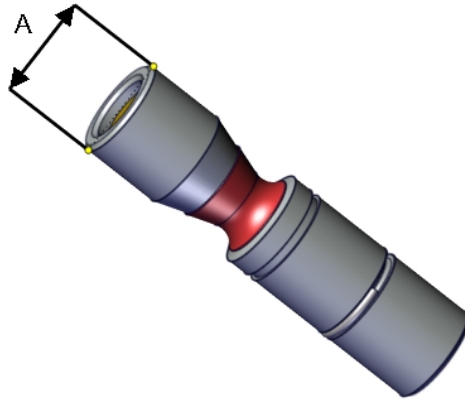

xx1500000951

A	Outer diameter
---	----------------

### 1.4.3.3 Installation locations for the calibration tools

#### Location of fixed calibration items

This section shows how the track is equipped with items for installation of calibration tools for Axis Calibration (fixed calibration pins and/or bushings). Installed calibration tools are not shown.

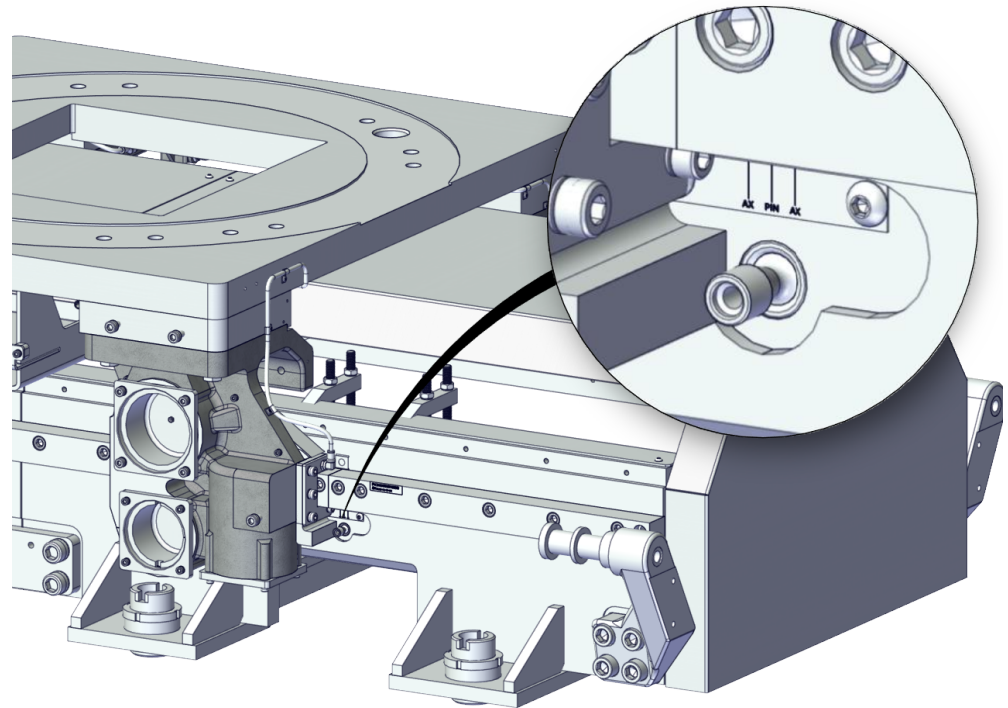

xx2200001157

# 1 Description

## 1.4.4 Pin calibration

### 1.4.4 Pin calibration

#### Location of calibration tool

The calibration tool is mounted on the track motion as shown in the figure.

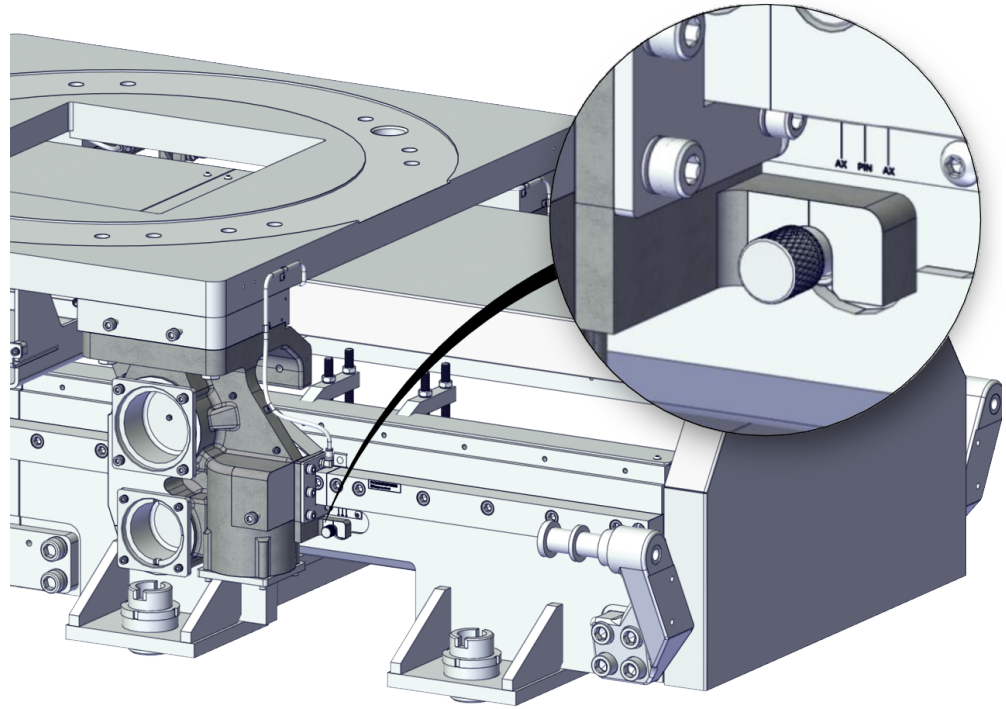

xx2200001158

#### Required equipment

Equipment etc.	Article number	Note
Calibration tool	3HAC042466-001	Attachment screws 9DA183-52 (M10x35), 2 pcs, required. Not included with the calibration tool.
Calibration tool, mirrored	3HAC042467-001	Attachment screw 9DA183-52 (M10x35), 1 pc, required. Not included with the calibration tool.
Cleaning agent	-	Isopropanol



## 1.5 Motion

### 1.5.1 Track type

---

#### Overview

The IRT 710 track motion can be categorized into three main types based on the carriage type and carriage quantity, that is, single carriage for robot/transfer, double carriages for robot/transfer and multiple carriages for transfer track. Travel length varies according to track motion types. For the travel length, see [IRT 710 carriage overview on page 21](#).

# 1 Description

## 1.5.2 Working range

### 1.5.2 Working range

#### Single carriage

Please check the layout of work range attached file and dimension information.

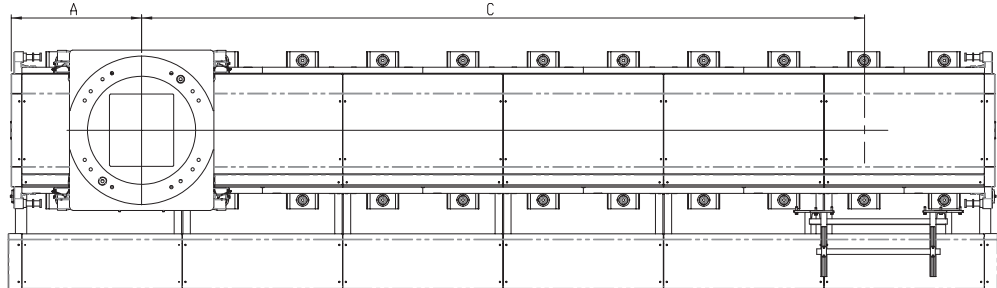

xx2200000401

Pos	Description
A	813 mm
C	Stroke

Carriage quantity is 1.				
First Carriage				
Track Length	Standard/Mirrored	Working range		Stroke
		Start	End	
3	Standard	-309	1197	1506
3	Mirrored	-309	1197	1506
3.5	Standard	-309	1697	2006
4	Standard	-309	2197	2506
4	Mirrored	-309	2197	2506
4.5	Standard	-309	2697	3006
5	Standard	-309	3197	3506
5	Mirrored	-309	3197	3506
5.5	Standard	-309	3697	4006
6	Standard	-309	4197	4506
6	Mirrored	-309	4197	4506
6.5	Standard	-309	4697	5006
7	Standard	-309	5197	5506
7	Mirrored	-309	5197	5506
7.5	Standard	-309	5697	6006
8	Standard	-309	6197	6506
8	Mirrored	-309	6197	6506
8.5	Standard	-309	6697	7006
9	Standard	-309	7197	7506
9	Mirrored	-309	7197	7506

Continues on next page

# 1 Description

## 1.5.2 Working range

*Continued*

Carriage quantity is 1.				
First Carriage				
Track Length	Stand- ard/Mirrored	Working range		Stroke
		Start	End	
9.5	Standard	-309	7697	8006
10	Standard	-309	8197	8506
10	Mirrored	-309	8197	8506
10.5	Standard	-309	8697	9006
11	Standard	-309	9197	9506
11	Mirrored	-309	9197	9506
11.5	Standard	-309	9697	10006
12	Standard	-309	10197	10506
12	Mirrored	-309	10197	10506
12.5	Standard	-309	10697	11006
13	Standard	-309	11197	11506
13	Mirrored	-309	11197	11506
13.5	Standard	-309	11697	12006
14	Standard	-309	12197	12506
14	Mirrored	-309	12197	12506
14.5	Standard	-309	12697	13006
15	Standard	-309	13197	13506
15	Mirrored	-309	13197	13506
15.5	Standard	-309	13697	14006
16	Standard	-309	14197	14506
16	Mirrored	-309	14197	14506
16.5	Standard	-309	14697	15006
17	Standard	-309	15197	15506
17	Mirrored	-309	15197	15506
17.5	Standard	-309	15697	16006
18	Standard	-309	16197	16506
18	Mirrored	-309	16197	16506
18.5	Standard	-309	16697	17006
19	Standard	-309	17197	17506
19	Mirrored	-309	17197	17506
19.5	Standard	-309	17697	18006
20	Standard	-309	18197	18506
20	Mirrored	-309	18197	18506
20.5	Standard	-309	18697	19006
21	Standard	-309	19197	19506

*Continues on next page*

# 1 Description

## 1.5.2 Working range

Continued

Carriage quantity is 1.				
First Carriage				
Track Length	Standard/Mirrored	Working range		Stroke
		Start	End	
21	Mirrored	-309	19197	19506
21.5	Standard	-309	19697	20006
22	Standard	-309	20197	20506
22	Mirrored	-309	20197	20506
22.5	Standard	-309	20697	21006
23	Standard	-309	21197	21506
23	Mirrored	-309	21197	21506
23.5	Standard	-309	21697	22006
24	Standard	-309	22197	22506
24	Mirrored	-309	22197	22506
24.5	Standard	-309	22697	23006
25	Standard	-309	23197	23506
25	Mirrored	-309	23197	23506
25.5	Standard	-309	23697	24006
26	Standard	-309	24197	24506
26	Mirrored	-309	24197	24506
26.5	Standard	-309	24697	25006
27	Standard	-309	25197	25506
27	Mirrored	-309	25197	25506
27.5	Standard	-309	25697	26006
28	Standard	-309	26197	26506
28	Mirrored	-309	26197	26506
28.5	Standard	-309	26697	27006
29	Standard	-309	27197	27506
29	Mirrored	-309	27197	27506
29.5	Standard	-309	27697	28006
30	Standard	-309	28197	28506
30	Mirrored	-309	28197	28506
30.5	Standard	-309	28697	29006
31	Standard	-309	29197	29506
31	Mirrored	-309	29197	29506
31.5	Standard	-309	29697	30006
32	Standard	-309	30197	30506
32	Mirrored	-309	30197	30506
32.5	Standard	-309	30697	31006

Continues on next page

# 1 Description

## 1.5.2 Working range

*Continued*

Carriage quantity is 1.				
First Carriage				
Track Length	Stand-ard/Mirrored	Working range		Stroke
		Start	End	
33	Standard	-309	31197	31506
33	Mirrored	-309	31197	31506
33.5	Standard	-309	31697	32006
34	Standard	-309	32197	32506
34	Mirrored	-309	32197	32506
34.5	Standard	-309	32697	33006
35	Standard	-309	33197	33506
35	Mirrored	-309	33197	33506
35.5	Standard	-309	33697	34006
36	Standard	-309	34197	34506
36	Mirrored	-309	34197	34506
36.5	Standard	-309	34697	35006
37	Standard	-309	35197	35506
37	Mirrored	-309	35197	35506
37.5	Standard	-309	35697	36006
38	Standard	-309	36197	36506
38	Mirrored	-309	36197	36506
38.5	Standard	-309	36697	37006
39	Standard	-309	37197	37506
39	Mirrored	-309	37197	37506
39.5	Standard	-309	37697	38006
40	Standard	-309	38197	38506
40	Mirrored	-309	38197	38506
40.5	Standard	-309	38697	39006

### Double carriages

Please check the layout of work range attached file and dimension information.

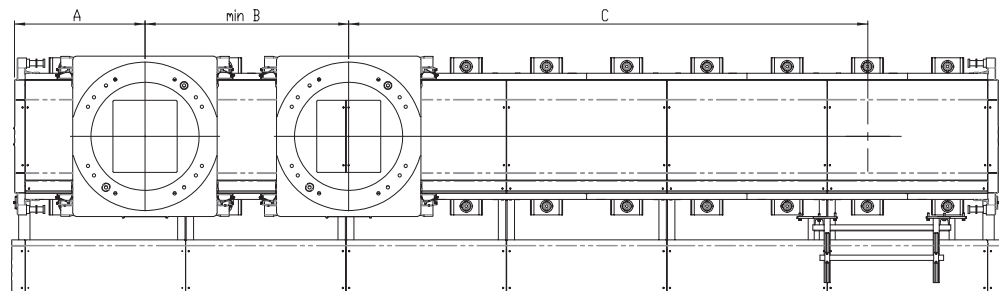

xx2200000402

*Continues on next page*

# 1 Description

## 1.5.2 Working range

Continued

Pos	Description
A	813 mm
Bmin	1270 mm
C	Stroke

Carriage quantity is 2.							
	First Carriage			Second Carriage			
	Stand-ard/Mirrored	Working range		Stand-ard/Mirrored	Working range		Stroke
Track Length		Start	End		Start	End	
4	Standard	-309	927	Standard	-1039	197	1236
4	Standard	-309	927	Mirrored	-309	927	1236
4	Mirrored	-1039	197	Mirrored	-309	927	1236
4.5	Standard	-309	1427	Standard	-1539	197	1736
5	Standard	-309	1927	Standard	-2039	197	2236
5	Standard	-309	1927	Mirrored	-309	1927	2236
5	Mirrored	-2039	197	Mirrored	-309	1927	2236
5.5	Standard	-309	2427	Standard	-2539	197	2736
6	Standard	-309	2927	Standard	-3039	197	3236
6	Standard	-309	2927	Mirrored	-309	2927	3236
6	Mirrored	-3039	197	Mirrored	-309	2927	3236
6.5	Standard	-309	3427	Standard	-3539	197	3736
7	Standard	-309	3927	Standard	-4039	197	4236
7	Standard	-309	3927	Mirrored	-309	3927	4236
7	Mirrored	-4039	197	Mirrored	-309	3927	4236
7.5	Standard	-309	4427	Standard	-4539	197	4736
8	Standard	-309	4927	Standard	-5039	197	5236
8	Standard	-309	4927	Mirrored	-309	4927	5236
8	Mirrored	-5039	197	Mirrored	-309	4927	5236
8.5	Standard	-309	5427	Standard	-5539	197	5736
9	Standard	-309	5927	Standard	-6039	197	6236
9	Standard	-309	5927	Mirrored	-309	5927	6236
9	Mirrored	-6039	197	Mirrored	-309	5927	6236
9.5	Standard	-309	6427	Standard	-6539	197	6736
10	Standard	-309	6927	Standard	-7039	197	7236
10	Standard	-309	6927	Mirrored	-309	6927	7236
10	Mirrored	-7039	197	Mirrored	-309	6927	7236
10.5	Standard	-309	7427	Standard	-7539	197	7736
11	Standard	-309	7927	Standard	-8039	197	8236
11	Standard	-309	7927	Mirrored	-309	7927	8236

Continues on next page

# 1 Description

## 1.5.2 Working range Continued

Carriage quantity is 2.							
	First Carriage			Second Carriage			
Track Length	Stand-ard/Mirrored	Working range		Stand-ard/Mirrored	Working range		Stroke
		Start	End		Start	End	
11	Mirrored	-8039	197	Mirrored	-309	7927	8236
11.5	Standard	-309	8427	Standard	-8539	197	8736
12	Standard	-309	8927	Standard	-9039	197	9236
12	Standard	-309	8927	Mirrored	-309	8927	9236
12	Mirrored	-9039	197	Mirrored	-309	8927	9236
12.5	Standard	-309	9427	Standard	-9539	197	9736
13	Standard	-309	9927	Standard	-10039	197	10236
13	Standard	-309	9927	Mirrored	-309	9927	10236
13	Mirrored	-10039	197	Mirrored	-309	9927	10236
13.5	Standard	-309	10427	Standard	-10539	197	10736
14	Standard	-309	10927	Standard	-11039	197	11236
14	Standard	-309	10927	Mirrored	-309	10927	11236
14	Mirrored	-11039	197	Mirrored	-309	10927	11236
14.5	Standard	-309	11427	Standard	-11539	197	11736
15	Standard	-309	11927	Standard	-12039	197	12236
15	Standard	-309	11927	Mirrored	-309	11927	12236
15	Mirrored	-12039	197	Mirrored	-309	11927	12236
15.5	Standard	-309	12427	Standard	-12539	197	12736
16	Standard	-309	12927	Standard	-13039	197	13236
16	Standard	-309	12927	Mirrored	-309	12927	13236
16	Mirrored	-13039	197	Mirrored	-309	12927	13236
16.5	Standard	-309	13427	Standard	-13539	197	13736
17	Standard	-309	13927	Standard	-14039	197	14236
17	Standard	-309	13927	Mirrored	-309	13927	14236
17	Mirrored	-14039	197	Mirrored	-309	13927	14236
17.5	Standard	-309	14427	Standard	-14539	197	14736
18	Standard	-309	14927	Standard	-15039	197	15236
18	Standard	-309	14927	Mirrored	-309	14927	15236
18	Mirrored	-15039	197	Mirrored	-309	14927	15236
18.5	Standard	-309	15427	Standard	-15539	197	15736
19	Standard	-309	15927	Standard	-16039	197	16236
19	Standard	-309	15927	Mirrored	-309	15927	16236
19	Mirrored	-16039	197	Mirrored	-309	15927	16236
19.5	Standard	-309	16427	Standard	-16539	197	16736

Continues on next page

# 1 Description

## 1.5.2 Working range

Continued

Carriage quantity is 2.							
	First Carriage			Second Carriage			
Track Length	Stand-ard/Mirrored	Working range		Stand-ard/Mirrored	Working range		Stroke
		Start	End		Start	End	
20	Standard	-309	16927	Standard	-17039	197	17236
20	Standard	-309	16927	Mirrored	-309	16927	17236
20	Mirrored	-17039	197	Mirrored	-309	16927	17236
20.5	Standard	-309	17427	Standard	-17539	197	17736
21	Standard	-309	17927	Standard	-18039	197	18236
21	Standard	-309	17927	Mirrored	-309	17927	18236
21	Mirrored	-18039	197	Mirrored	-309	17927	18236
21.5	Standard	-309	18427	Standard	-18539	197	18736
22	Standard	-309	18927	Standard	-19039	197	19236
22	Standard	-309	18927	Mirrored	-309	18927	19236
22	Mirrored	-19039	197	Mirrored	-309	18927	19236
22.5	Standard	-309	19427	Standard	-19539	197	19736
23	Standard	-309	19927	Standard	-20039	197	20236
23	Standard	-309	19927	Mirrored	-309	19927	20236
23	Mirrored	-20039	197	Mirrored	-309	19927	20236
23.5	Standard	-309	20427	Standard	-20539	197	20736
24	Standard	-309	20927	Standard	-21039	197	21236
24	Standard	-309	20927	Mirrored	-309	20927	21236
24	Mirrored	-21039	197	Mirrored	-309	20927	21236
24.5	Standard	-309	21427	Standard	-21539	197	21736
25	Standard	-309	21927	Standard	-22039	197	22236
25	Standard	-309	21927	Mirrored	-309	21927	22236
25	Mirrored	-22039	197	Mirrored	-309	21927	22236
25.5	Standard	-309	22427	Standard	-22539	197	22736
26	Standard	-309	22927	Standard	-23039	197	23236
26	Standard	-309	22927	Mirrored	-309	22927	23236
26	Mirrored	-23039	197	Mirrored	-309	22927	23236
26.5	Standard	-309	23427	Standard	-23539	197	23736
27	Standard	-309	23927	Standard	-24039	197	24236
27	Standard	-309	23927	Mirrored	-309	23927	24236
27	Mirrored	-24039	197	Mirrored	-309	23927	24236
27.5	Standard	-309	24427	Standard	-24539	197	24736
28	Standard	-309	24927	Standard	-25039	197	25236
28	Standard	-309	24927	Mirrored	-309	24927	25236

Continues on next page



# 1 Description

## 1.5.2 Working range

*Continued*

Carriage quantity is 2.							
Track Length	First Carriage			Second Carriage			Stroke
	Stand-ard/Mirrored	Working range		Stand-ard/Mirrored	Working range		
		Start	End		Start	End	
28	Mirrored	-25039	197	Mirrored	-309	24927	25236
28.5	Standard	-309	25427	Standard	-25539	197	25736
29	Standard	-309	25927	Standard	-26039	197	26236
29	Standard	-309	25927	Mirrored	-309	25927	26236
29	Mirrored	-26039	197	Mirrored	-309	25927	26236
29.5	Standard	-309	26427	Standard	-26539	197	26736
30	Standard	-309	26927	Standard	-27039	197	27236
30	Standard	-309	26927	Mirrored	-309	26927	27236
30	Mirrored	-27039	197	Mirrored	-309	26927	27236
30.5	Standard	-309	27427	Standard	-27539	197	27736
31	Standard	-309	27927	Standard	-28039	197	28236
31	Standard	-309	27927	Mirrored	-309	27927	28236
31	Mirrored	-28039	197	Mirrored	-309	27927	28236
31.5	Standard	-309	28427	Standard	-28539	197	28736
32	Standard	-309	28927	Standard	-29039	197	29236
32	Standard	-309	28927	Mirrored	-309	28927	29236
32	Mirrored	-29039	197	Mirrored	-309	28927	29236
32.5	Standard	-309	29427	Standard	-29539	197	29736
33	Standard	-309	29927	Standard	-30039	197	30236
33	Standard	-309	29927	Mirrored	-309	29927	30236
33	Mirrored	-30039	197	Mirrored	-309	29927	30236
33.5	Standard	-309	30427	Standard	-30539	197	30736
34	Standard	-309	30927	Standard	-31039	197	31236
34	Standard	-309	30927	Mirrored	-309	30927	31236
34	Mirrored	-31039	197	Mirrored	-309	30927	31236
34.5	Standard	-309	31427	Standard	-31539	197	31736
35	Standard	-309	31927	Standard	-32039	197	32236
35	Standard	-309	31927	Mirrored	-309	31927	32236
35	Mirrored	-32039	197	Mirrored	-309	31927	32236
35.5	Standard	-309	32427	Standard	-32539	197	32736
36	Standard	-309	32927	Standard	-33039	197	33236
36	Standard	-309	32927	Mirrored	-309	32927	33236
36	Mirrored	-33039	197	Mirrored	-309	32927	33236
36.5	Standard	-309	33427	Standard	-33539	197	33736

*Continues on next page*

# 1 Description

## 1.5.2 Working range

Continued

Carriage quantity is 2.							
	First Carriage			Second Carriage			
Track Length	Stand-ard/Mirrored	Working range		Stand-ard/Mirrored	Working range		Stroke
		Start	End		Start	End	
37	Standard	-309	33927	Standard	-34039	197	34236
37	Standard	-309	33927	Mirrored	-309	33927	34236
37	Mirrored	-34039	197	Mirrored	-309	33927	34236
37.5	Standard	-309	34427	Standard	-34539	197	34736
38	Standard	-309	34927	Standard	-35039	197	35236
38	Standard	-309	34927	Mirrored	-309	34927	35236
38	Mirrored	-35039	197	Mirrored	-309	34927	35236
38.5	Standard	-309	35427	Standard	-35539	197	35736
39	Standard	-309	35927	Standard	-36039	197	36236
39	Standard	-309	35927	Mirrored	-309	35927	36236
39	Mirrored	-36039	197	Mirrored	-309	35927	36236
39.5	Standard	-309	36427	Standard	-36539	197	36736
40	Standard	-309	36927	Standard	-37039	197	37236
40	Standard	-309	36927	Mirrored	-309	36927	37236
40	Mirrored	-37039	197	Mirrored	-309	36927	37236
40.5	Standard	-309	37427	Standard	-37539	197	37736

### Three carriages

Please check the layout of work range attached file and dimension information.

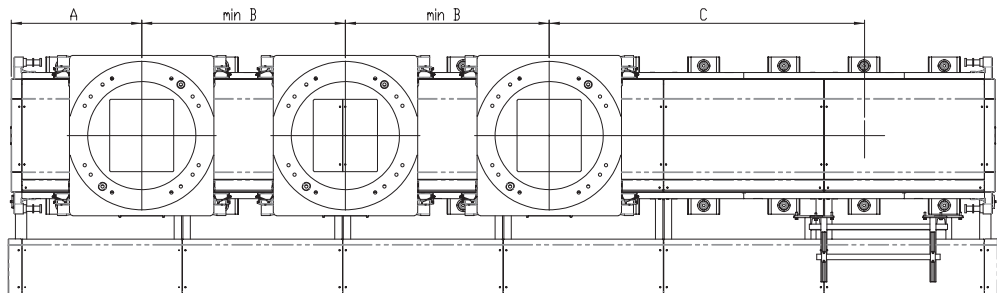

xx2200000403

Pos	Description
A	813 mm
Bmin	1270 mm
C	Stroke

Continues on next page

Carriage quantity is 3.

Track Length	First Carriage			Second Carriage			Third Carriage			Stroke
	Standard/Mirrored	Working range		Standard/Mirrored	Working range		Standard/Mirrored	Working range		
		Start	End		Start	End		Start	End	
6	Standard	-309	1657	Standard	-1769	197	Standard	-1039	927	1966
6	Mirrored	-1769	197	Mirrored	-309	1657	Mirrored	-1039	927	1966
6.5	Standard	-309	2157	Standard	-2269	197	Standard	-1039	1427	2466
7	Standard	-309	2657	Standard	-2769	197	Standard	-1039	1927	2966
7	Mirrored	-2769	197	Mirrored	-309	2657	Mirrored	-2039	927	2966
7.5	Standard	-309	3157	Standard	-3269	197	Standard	-1039	2427	3466
8	Standard	-309	3657	Standard	-3769	197	Standard	-1039	2927	3966
8	Mirrored	-3769	197	Mirrored	-309	3657	Mirrored	-3039	927	3966
8.5	Standard	-309	4157	Standard	-4269	197	Standard	-1039	3427	4466
9	Standard	-309	4657	Standard	-4769	197	Standard	-1039	3927	4966
9	Mirrored	-4769	197	Mirrored	-309	4657	Mirrored	-4039	927	4966
9.5	Standard	-309	5157	Standard	-5269	197	Standard	-1039	4427	5466
10	Standard	-309	5657	Standard	-5769	197	Standard	-1039	4927	5966
10	Mirrored	-5769	197	Mirrored	-309	5657	Mirrored	-5039	927	5966
10.5	Standard	-309	6157	Standard	-6269	197	Standard	-1039	5427	6466
11	Standard	-309	6657	Standard	-6769	197	Standard	-1039	5927	6966
11	Mirrored	-6769	197	Mirrored	-309	6657	Mirrored	-6039	927	6966
11.5	Standard	-309	7157	Standard	-7269	197	Standard	-1039	6427	7466
12	Standard	-309	7657	Standard	-7769	197	Standard	-1039	6927	7966
12	Mirrored	-7769	197	Mirrored	-309	7657	Mirrored	-7039	927	7966
12.5	Standard	-309	8157	Standard	-8269	197	Standard	-1039	7427	8466
13	Standard	-309	8657	Standard	-8769	197	Standard	-1039	7927	8966
13	Mirrored	-8769	197	Mirrored	-309	8657	Mirrored	-8039	927	8966
13.5	Standard	-309	9157	Standard	-9269	197	Standard	-1039	8427	9466
14	Standard	-309	9657	Standard	-9769	197	Standard	-1039	8927	9966
14	Mirrored	-9769	197	Mirrored	-309	9657	Mirrored	-9039	927	9966
14.5	Standard	-309	10157	Standard	-10269	197	Standard	-1039	9427	10466
15	Standard	-309	10657	Standard	-10769	197	Standard	-1039	9927	10966
15	Mirrored	-10769	197	Mirrored	-309	10657	Mirrored	-10039	927	10966
15.5	Standard	-309	11157	Standard	-11269	197	Standard	-1039	10427	11466
16	Standard	-309	11657	Standard	-11769	197	Standard	-1039	10927	11966
16	Mirrored	-11769	197	Mirrored	-309	11657	Mirrored	-11039	927	11966
16.5	Standard	-309	12157	Standard	-12269	197	Standard	-1039	11427	12466
17	Standard	-309	12657	Standard	-12769	197	Standard	-1039	11927	12966
17	Mirrored	-12769	197	Mirrored	-309	12657	Mirrored	-12039	927	12966

Continues on next page

# 1 Description

## 1.5.2 Working range

Carriage quantity is 3.										
Track Length	First Carriage			Second Carriage			Third Carriage			Stroke
	Standard/Mirrored	Working range		Standard/Mirrored	Working range		Standard/Mirrored	Working range		
		Start	End		Start	End		Start	End	
17.5	Standard	-309	13157	Standard	-13269	197	Standard	-1039	12427	13466
18	Standard	-309	13657	Standard	-13769	197	Standard	-1039	12927	13966
18	Mirrored	-13769	197	Mirrored	-309	13657	Mirrored	-13039	927	13966
18.5	Standard	-309	14157	Standard	-14269	197	Standard	-1039	13427	14466
19	Standard	-309	14657	Standard	-14769	197	Standard	-1039	13927	14966
19	Mirrored	-14769	197	Mirrored	-309	14657	Mirrored	-14039	927	14966
19.5	Standard	-309	15157	Standard	-15269	197	Standard	-1039	14427	15466
20	Standard	-309	15657	Standard	-15769	197	Standard	-1039	14927	15966
20	Mirrored	-15769	197	Mirrored	-309	15657	Mirrored	-15039	927	15966
20.5	Standard	-309	16157	Standard	-16269	197	Standard	-1039	15427	16466
21	Standard	-309	16657	Standard	-16769	197	Standard	-1039	15927	16966
21	Mirrored	-16769	197	Mirrored	-309	16657	Mirrored	-16039	927	16966
21.5	Standard	-309	17157	Standard	-17269	197	Standard	-1039	16427	17466
22	Standard	-309	17657	Standard	-17769	197	Standard	-1039	16927	17966
22	Mirrored	-17769	197	Mirrored	-309	17657	Mirrored	-17039	927	17966
22.5	Standard	-309	18157	Standard	-18269	197	Standard	-1039	17427	18466
23	Standard	-309	18657	Standard	-18769	197	Standard	-1039	17927	18966
23	Mirrored	-18769	197	Mirrored	-309	18657	Mirrored	-18039	927	18966
23.5	Standard	-309	19157	Standard	-19269	197	Standard	-1039	18427	19466
24	Standard	-309	19657	Standard	-19769	197	Standard	-1039	18927	19966
24	Mirrored	-19769	197	Mirrored	-309	19657	Mirrored	-19039	927	19966
24.5	Standard	-309	20157	Standard	-20269	197	Standard	-1039	19427	20466
25	Standard	-309	20657	Standard	-20769	197	Standard	-1039	19927	20966
25	Mirrored	-20769	197	Mirrored	-309	20657	Mirrored	-20039	927	20966
25.5	Standard	-309	21157	Standard	-21269	197	Standard	-1039	20427	21466
26	Standard	-309	21657	Standard	-21769	197	Standard	-1039	20927	21966
26	Mirrored	-21769	197	Mirrored	-309	21657	Mirrored	-21039	927	21966
26.5	Standard	-309	22157	Standard	-22269	197	Standard	-1039	21427	22466
27	Standard	-309	22657	Standard	-22769	197	Standard	-1039	21927	22966
27	Mirrored	-22769	197	Mirrored	-309	22657	Mirrored	-22039	927	22966
27.5	Standard	-309	23157	Standard	-23269	197	Standard	-1039	22427	23466
28	Standard	-309	23657	Standard	-23769	197	Standard	-1039	22927	23966
28	Mirrored	-23769	197	Mirrored	-309	23657	Mirrored	-23039	927	23966
28.5	Standard	-309	24157	Standard	-24269	197	Standard	-1039	23427	24466
29	Standard	-309	24657	Standard	-24769	197	Standard	-1039	23927	24966

Continues on next page

Carriage quantity is 3.										
Track Length	First Carriage			Second Carriage			Third Carriage			Stroke
	Standard/Mirrored	Working range		Standard/Mirrored	Working range		Standard/Mirrored	Working range		
		Start	End		Start	End		Start	End	
29	Mirrored	-24769	197	Mirrored	-309	24657	Mirrored	-24039	927	24966
29.5	Standard	-309	25157	Standard	-25269	197	Standard	-1039	24427	25466
30	Standard	-309	25657	Standard	-25769	197	Standard	-1039	24927	25966
30	Mirrored	-25769	197	Mirrored	-309	25657	Mirrored	-25039	927	25966
30.5	Standard	-309	26157	Standard	-26269	197	Standard	-1039	25427	26466
31	Standard	-309	26657	Standard	-26769	197	Standard	-1039	25927	26966
31	Mirrored	-26769	197	Mirrored	-309	26657	Mirrored	-26039	927	26966
31.5	Standard	-309	27157	Standard	-27269	197	Standard	-1039	26427	27466
32	Standard	-309	27657	Standard	-27769	197	Standard	-1039	26927	27966
32	Mirrored	-27769	197	Mirrored	-309	27657	Mirrored	-27039	927	27966
32.5	Standard	-309	28157	Standard	-28269	197	Standard	-1039	27427	28466
33	Standard	-309	28657	Standard	-28769	197	Standard	-1039	27927	28966
33	Mirrored	-28769	197	Mirrored	-309	28657	Mirrored	-28039	927	28966
33.5	Standard	-309	29157	Standard	-29269	197	Standard	-1039	28427	29466
34	Standard	-309	29657	Standard	-29769	197	Standard	-1039	28927	29966
34	Mirrored	-29769	197	Mirrored	-309	29657	Mirrored	-29039	927	29966
34.5	Standard	-309	30157	Standard	-30269	197	Standard	-1039	29427	30466
35	Standard	-309	30657	Standard	-30769	197	Standard	-1039	29927	30966
35	Mirrored	-30769	197	Mirrored	-309	30657	Mirrored	-30039	927	30966
35.5	Standard	-309	31157	Standard	-31269	197	Standard	-1039	30427	31466
36	Standard	-309	31657	Standard	-31769	197	Standard	-1039	30927	31966
36	Mirrored	-31769	197	Mirrored	-309	31657	Mirrored	-31039	927	31966
36.5	Standard	-309	32157	Standard	-32269	197	Standard	-1039	31427	32466
37	Standard	-309	32657	Standard	-32769	197	Standard	-1039	31927	32966
37	Mirrored	-32769	197	Mirrored	-309	32657	Mirrored	-32039	927	32966
37.5	Standard	-309	33157	Standard	-33269	197	Standard	-1039	32427	33466
38	Standard	-309	33657	Standard	-33769	197	Standard	-1039	32927	33966
38	Mirrored	-33769	197	Mirrored	-309	33657	Mirrored	-33039	927	33966
38.5	Standard	-309	34157	Standard	-34269	197	Standard	-1039	33427	34466
39	Standard	-309	34657	Standard	-34769	197	Standard	-1039	33927	34966
39	Mirrored	-34769	197	Mirrored	-309	34657	Mirrored	-34039	927	34966
39.5	Standard	-309	35157	Standard	-35269	197	Standard	-1039	34427	35466
40	Standard	-309	35657	Standard	-35769	197	Standard	-1039	34927	35966
40	Mirrored	-35769	197	Mirrored	-309	35657	Mirrored	-35039	927	35966
40.5	Standard	-309	36157	Standard	-36269	197	Standard	-1039	35427	36466

Continues on next page

# 1 Description

## 1.5.2 Working range

### Four carriages

Please check the layout of work range attached file and dimension information.

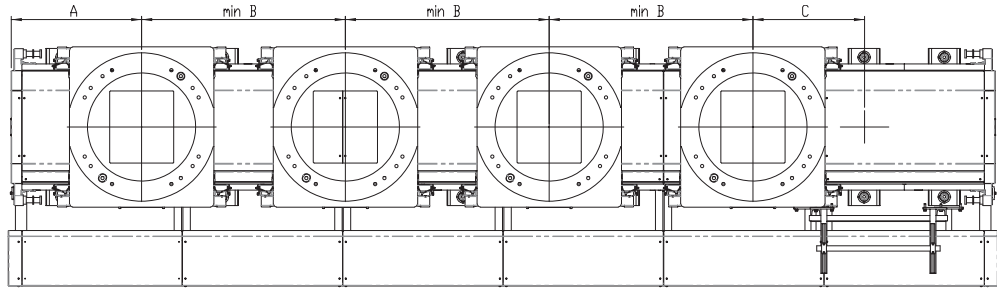

xx2200000404

Pos	Description
A	813 mm
Bmin	1270 mm
C	Stroke

*Continues on next page*

Carriage quantity is 4.													
	First Carriage			Second Carriage			Third Carriage			Fourth Carriage			
	Stand-ard/Mirrored	Working range		Stand-ard/Mirrored	Working range		Stand-ard/Mirrored	Working range		Stand-ard/Mirrored	Working range		Stroke
Track Length		Start	End		Start	End		Start	End		Start	End	
8	Standard	-309	2387	Standard	-2499	197	Standard	-1039	1657	Standard	-1769	927	2696
8	Mirrored	-2499	197	Mirrored	-309	2387	Mirrored	-1769	927	Mirrored	-1039	1657	2696
8.5	Standard	-309	2887	Standard	-2999	197	Standard	-1039	2157	Standard	-2269	927	3196
9	Standard	-309	3387	Standard	-3499	197	Standard	-1039	2657	Standard	-2769	927	3696
9	Mirrored	-3499	197	Mirrored	-309	3387	Mirrored	-2769	927	Mirrored	-1039	2657	3696
9.5	Standard	-309	3887	Standard	-3999	197	Standard	-1039	3157	Standard	-3269	927	4196
10	Standard	-309	4387	Standard	-4499	197	Standard	-1039	3657	Standard	-3769	927	4696
10	Mirrored	-4499	197	Mirrored	-309	4387	Mirrored	-3769	927	Mirrored	-1039	3657	4696
10.5	Standard	-309	4887	Standard	-4999	197	Standard	-1039	4157	Standard	-4269	927	5196
11	Standard	-309	5387	Standard	-5499	197	Standard	-1039	4657	Standard	-4769	927	5696
11	Mirrored	-5499	197	Mirrored	-309	5387	Mirrored	-4769	927	Mirrored	-1039	4657	5696
11.5	Standard	-309	5887	Standard	-5999	197	Standard	-1039	5157	Standard	-5269	927	6196
12	Standard	-309	6387	Standard	-6499	197	Standard	-1039	5657	Standard	-5769	927	6696
12	Mirrored	-6499	197	Mirrored	-309	6387	Mirrored	-5769	927	Mirrored	-1039	5657	6696
12.5	Standard	-309	6887	Standard	-6999	197	Standard	-1039	6157	Standard	-6269	927	7196
13	Standard	-309	7387	Standard	-7499	197	Standard	-1039	6657	Standard	-6769	927	7696
13	Mirrored	-7499	197	Mirrored	-309	7387	Mirrored	-6769	927	Mirrored	-1039	6657	7696
13.5	Standard	-309	7887	Standard	-7999	197	Standard	-1039	7157	Standard	-7269	927	8196
14	Standard	-309	8387	Standard	-8499	197	Standard	-1039	7657	Standard	-7769	927	8696
14	Mirrored	-8499	197	Mirrored	-309	8387	Mirrored	-7769	927	Mirrored	-1039	7657	8696
14.5	Standard	-309	8887	Standard	-8999	197	Standard	-1039	8157	Standard	-8269	927	9196
15	Standard	-309	9387	Standard	-9499	197	Standard	-1039	8657	Standard	-8769	927	9696
15	Mirrored	-9499	197	Mirrored	-309	9387	Mirrored	-8769	927	Mirrored	-1039	8657	9696
15.5	Standard	-309	9887	Standard	-9999	197	Standard	-1039	9157	Standard	-9269	927	10196
16	Standard	-309	10387	Standard	-10499	197	Standard	-1039	9657	Standard	-9769	927	10696
16	Mirrored	-10499	197	Mirrored	-309	10387	Mirrored	-9769	927	Mirrored	-1039	9657	10696
16.5	Standard	-309	10887	Standard	-10999	197	Standard	-1039	10157	Standard	-10269	927	11196
17	Standard	-309	11387	Standard	-11499	197	Standard	-1039	10657	Standard	-10769	927	11696
17	Mirrored	-11499	197	Mirrored	-309	11387	Mirrored	-10769	927	Mirrored	-1039	10657	11696
17.5	Standard	-309	11887	Standard	-11999	197	Standard	-1039	11157	Standard	-11269	927	12196
18	Standard	-309	12387	Standard	-12499	197	Standard	-1039	11657	Standard	-11769	927	12696
18	Mirrored	-12499	197	Mirrored	-309	12387	Mirrored	-11769	927	Mirrored	-1039	11657	12696
18.5	Standard	-309	12887	Standard	-12999	197	Standard	-1039	12157	Standard	-12269	927	13196
19	Standard	-309	13387	Standard	-13499	197	Standard	-1039	12657	Standard	-12769	927	13696
19	Mirrored	-13499	197	Mirrored	-309	13387	Mirrored	-12769	927	Mirrored	-1039	12657	13696

Continues on next page

# 1 Description

## 1.5.2 Working range

Carriage quantity is 4.													
	First Carriage			Second Carriage			Third Carriage			Fourth Carriage			
	Stand-ard/Mirrored	Working range		Stand-ard/Mirrored	Working range		Stand-ard/Mirrored	Working range		Stand-ard/Mirrored	Working range		Stroke
Track Length		Start	End		Start	End		Start	End		Start	End	
19.5	Standard	-309	13887	Standard	-13999	197	Standard	-1039	13157	Standard	-13269	927	14196
20	Standard	-309	14387	Standard	-14499	197	Standard	-1039	13657	Standard	-13769	927	14696
20	Mirrored	-14499	197	Mirrored	-309	14387	Mirrored	-13769	927	Mirrored	-1039	13657	14696
20.5	Standard	-309	14887	Standard	-14999	197	Standard	-1039	14157	Standard	-14269	927	15196
21	Standard	-309	15387	Standard	-15499	197	Standard	-1039	14657	Standard	-14769	927	15696
21	Mirrored	-15499	197	Mirrored	-309	15387	Mirrored	-14769	927	Mirrored	-1039	14657	15696
21.5	Standard	-309	15887	Standard	-15999	197	Standard	-1039	15157	Standard	-15269	927	16196
22	Standard	-309	16387	Standard	-16499	197	Standard	-1039	15657	Standard	-15769	927	16696
22	Mirrored	-16499	197	Mirrored	-309	16387	Mirrored	-15769	927	Mirrored	-1039	15657	16696
22.5	Standard	-309	16887	Standard	-16999	197	Standard	-1039	16157	Standard	-16269	927	17196
23	Standard	-309	17387	Standard	-17499	197	Standard	-1039	16657	Standard	-16769	927	17696
23	Mirrored	-17499	197	Mirrored	-309	17387	Mirrored	-16769	927	Mirrored	-1039	16657	17696
23.5	Standard	-309	17887	Standard	-17999	197	Standard	-1039	17157	Standard	-17269	927	18196
24	Standard	-309	18387	Standard	-18499	197	Standard	-1039	17657	Standard	-17769	927	18696
24	Mirrored	-18499	197	Mirrored	-309	18387	Mirrored	-17769	927	Mirrored	-1039	17657	18696
24.5	Standard	-309	18887	Standard	-18999	197	Standard	-1039	18157	Standard	-18269	927	19196
25	Standard	-309	19387	Standard	-19499	197	Standard	-1039	18657	Standard	-18769	927	19696
25	Mirrored	-19499	197	Mirrored	-309	19387	Mirrored	-18769	927	Mirrored	-1039	18657	19696
25.5	Standard	-309	19887	Standard	-19999	197	Standard	-1039	19157	Standard	-19269	927	20196
26	Standard	-309	20387	Standard	-20499	197	Standard	-1039	19657	Standard	-19769	927	20696
26	Mirrored	-20499	197	Mirrored	-309	20387	Mirrored	-19769	927	Mirrored	-1039	19657	20696
26.5	Standard	-309	20887	Standard	-20999	197	Standard	-1039	20157	Standard	-20269	927	21196
27	Standard	-309	21387	Standard	-21499	197	Standard	-1039	20657	Standard	-20769	927	21696
27	Mirrored	-21499	197	Mirrored	-309	21387	Mirrored	-20769	927	Mirrored	-1039	20657	21696
27.5	Standard	-309	21887	Standard	-21999	197	Standard	-1039	21157	Standard	-21269	927	22196
28	Standard	-309	22387	Standard	-22499	197	Standard	-1039	21657	Standard	-21769	927	22696
28	Mirrored	-22499	197	Mirrored	-309	22387	Mirrored	-21769	927	Mirrored	-1039	21657	22696
28.5	Standard	-309	22887	Standard	-22999	197	Standard	-1039	22157	Standard	-22269	927	23196
29	Standard	-309	23387	Standard	-23499	197	Standard	-1039	22657	Standard	-22769	927	23696
29	Mirrored	-23499	197	Mirrored	-309	23387	Mirrored	-22769	927	Mirrored	-1039	22657	23696
29.5	Standard	-309	23887	Standard	-23999	197	Standard	-1039	23157	Standard	-23269	927	24196
30	Standard	-309	24387	Standard	-24499	197	Standard	-1039	23657	Standard	-23769	927	24696
30	Mirrored	-24499	197	Mirrored	-309	24387	Mirrored	-23769	927	Mirrored	-1039	23657	24696
30.5	Standard	-309	24887	Standard	-24999	197	Standard	-1039	24157	Standard	-24269	927	25196
31	Standard	-309	25387	Standard	-25499	197	Standard	-1039	24657	Standard	-24769	927	25696

Continues on next page



Carriage quantity is 4.													
	First Carriage			Second Carriage			Third Carriage			Fourth Carriage			
	Stand-ard/Mirrored	Working range		Stand-ard/Mirrored	Working range		Stand-ard/Mirrored	Working range		Stand-ard/Mirrored	Working range		Stroke
Track Length		Start	End		Start	End		Start	End		Start	End	
31	Mirrored	-25499	197	Mirrored	-309	25387	Mirrored	-24769	927	Mirrored	-1039	24657	25696
31.5	Standard	-309	25887	Standard	-25999	197	Standard	-1039	25157	Standard	-25269	927	26196
32	Standard	-309	26387	Standard	-26499	197	Standard	-1039	25657	Standard	-25769	927	26696
32	Mirrored	-26499	197	Mirrored	-309	26387	Mirrored	-25769	927	Mirrored	-1039	25657	26696
32.5	Standard	-309	26887	Standard	-26999	197	Standard	-1039	26157	Standard	-26269	927	27196
33	Standard	-309	27387	Standard	-27499	197	Standard	-1039	26657	Standard	-26769	927	27696
33	Mirrored	-27499	197	Mirrored	-309	27387	Mirrored	-26769	927	Mirrored	-1039	26657	27696
33.5	Standard	-309	27887	Standard	-27999	197	Standard	-1039	27157	Standard	-27269	927	28196
34	Standard	-309	28387	Standard	-28499	197	Standard	-1039	27657	Standard	-27769	927	28696
34	Mirrored	-28499	197	Mirrored	-309	28387	Mirrored	-27769	927	Mirrored	-1039	27657	28696
34.5	Standard	-309	28887	Standard	-28999	197	Standard	-1039	28157	Standard	-28269	927	29196
35	Standard	-309	29387	Standard	-29499	197	Standard	-1039	28657	Standard	-28769	927	29696
35	Mirrored	-29499	197	Mirrored	-309	29387	Mirrored	-28769	927	Mirrored	-1039	28657	29696
35.5	Standard	-309	29887	Standard	-29999	197	Standard	-1039	29157	Standard	-29269	927	30196
36	Standard	-309	30387	Standard	-30499	197	Standard	-1039	29657	Standard	-29769	927	30696
36	Mirrored	-30499	197	Mirrored	-309	30387	Mirrored	-29769	927	Mirrored	-1039	29657	30696
36.5	Standard	-309	30887	Standard	-30999	197	Standard	-1039	30157	Standard	-30269	927	31196
37	Standard	-309	31387	Standard	-31499	197	Standard	-1039	30657	Standard	-30769	927	31696
37	Mirrored	-31499	197	Mirrored	-309	31387	Mirrored	-30769	927	Mirrored	-1039	30657	31696
37.5	Standard	-309	31887	Standard	-31999	197	Standard	-1039	31157	Standard	-31269	927	32196
38	Standard	-309	32387	Standard	-32499	197	Standard	-1039	31657	Standard	-31769	927	32696
38	Mirrored	-32499	197	Mirrored	-309	32387	Mirrored	-31769	927	Mirrored	-1039	31657	32696
38.5	Standard	-309	32887	Standard	-32999	197	Standard	-1039	32157	Standard	-32269	927	33196
39	Standard	-309	33387	Standard	-33499	197	Standard	-1039	32657	Standard	-32769	927	33696
39	Mirrored	-33499	197	Mirrored	-309	33387	Mirrored	-32769	927	Mirrored	-1039	32657	33696
39.5	Standard	-309	33887	Standard	-33999	197	Standard	-1039	33157	Standard	-33269	927	34196
40	Standard	-309	34387	Standard	-34499	197	Standard	-1039	33657	Standard	-33769	927	34696
40	Mirrored	-34499	197	Mirrored	-309	34387	Mirrored	-33769	927	Mirrored	-1039	33657	34696
40.5	Standard	-309	34887	Standard	-34999	197	Standard	-1039	34157	Standard	-34269	927	35196

Continues on next page

# 1 Description

---

## 1.5.3 Performance

### 1.5.3 Performance

---

#### General

The following table describes the dynamic performances of the IRT 710.

IRT 710	Performance
Pose repeatability (mm)	$\leq \pm 0.02$
Max. acceleration ( $m/s^2$ )	Transfer carriage or Large robot support: up to $2m/s^2$
	Medium robot support: up to $2.5m/s^2$

**1.5.4 Velocity**

---

**Maximum axis speeds**

<b>IRT 710</b>	<b>Performance</b>
Transfer carriage or Large robot support (IRB 7600, IRB 6650S, IRB 6660, IRB 6700, IRB 6620, IRB 660, IRB 460) support	1.8 m/s
Medium robot support (IRB 4600)	2.0 m/s
Medium robot support (IRB 4400)	1.43 m/s

# 1 Description

---

## 1.5.5 Positioning time

### 1.5.5 Positioning time

---

#### Positioning time at different travel length

The following table describes the typical positioning times.

Load	Travel length (m)								
	1	2	3	4	5	6	7	8	9
Max payload (3000 kg ) ) <sup>i</sup>	1.67 s <sup>i</sup>	2.3 s	2.86 s	3.41 s	3.97 s	4.53 s	5.08 s	5.64 s	6.19 s

<sup>i</sup> The distance is too short for the carriage to reach its maximum speed.

**1.5.6 Stopping distance/time****General**

The following table describes the stopping distances and time.

		3000 kg payload
Category 0	Stopping time (s)	0.93
	Distance (m)	0.90
Category 1	Stopping time (s)	1.47
	Distance (m)	1.57

# 1 Description

---

## 1.5.7 Thermal performance

### 1.5.7 Thermal performance

---

#### General

The IRT 710 is designed for intermittent operation. It is not meant to continuously accelerate/decelerate. The latter can result in overheating of the track motor which will lead to a stop of the system or possibly a motor failure due to overheating. Contact your local ABB Robotics office for advice in case of applications with high duty cycles.

### 1.6 Maintenance and troubleshooting

---

#### General

The IRT 710 requires only minimum maintenance during operation. It has been designed to make it as easy to service as possible:

- Maintenance-free AC motors are used.
- Grease is used for the rack & pinion, rectangular rail and cam roller.
- The cabling is routed for longevity, and in the unlikely event of a failure, its modular design makes it easy to change.

---

#### Maintenance

The maintenance intervals depend on the use of the IRT 710. The required maintenance activities also depend on the selected options. For detailed information on maintenance procedures, see the maintenance section in product manual.

**This page is intentionally left blank**



## 2 Specification of variants and options

### 2.1 Introduction to variants and options

---

#### General

Different variants and options for the IRT 710 are described in the following sections. The same option numbers are used here as in the specification form.

---

#### Related information

For the controller, see *Product specification - Controller IRC5 with FlexPendant*.  
For the software options, see *Product specification - Controller software IRC5*.

## 2 Specification of variants and options

---

### 2.2 Track motion type

### 2.2 Track motion type

---

#### Carriage quantity

Option	Description	Note
1700-1	Carriage quantity	Choose quantity (1-4), mandatory option.

---

#### Track length - 1.0 m

Option	Description	Note
1701-1	Track length	Choose length (3-40), mandatory option.

---

#### Additional 0.5 m

Option	Description	Note
1702-1	Covered track - 0.5m	

---

#### External cable chain Position

Option	Description	Note
1703-1	Mounted left handed	
1703-2	Mounted right handed	

#### Limitation

If carriage quantity is 1 or 2 and [1703-x] is selected, the position of the cable chain is outside of the track. If [1703-x] is not selected, the cable chain is inside of the track.

If carriage quantity is 3 or 4, option [1703-x] must be selected, the option [1703-x] define the position of the cable chain for the 3<sup>rd</sup> and 4<sup>th</sup> carriage. The cable chain of 1<sup>st</sup> and 2<sup>nd</sup> carriage is in the middle by default.

---

#### Track color

Option	Color	RAL code <sup>i</sup>
209-1	ABB Orange	NCS 2070-Y60R
209-202	ABB Graphite White std (Default value, standard color)	RAL 7035

<sup>i</sup> The colors can differ depending on supplier and the material on which the paint is applied.

*Continues on next page*

### Warranty

For the selected period of time, ABB will provide spare parts and labour to repair or replace the non-conforming portion of the equipment without additional charges. During that period, it is required to have a yearly Preventative Maintenance according to ABB manuals to be performed by ABB. If due to customer restrains no data can be analyzed in the ABB Ability service *Condition Monitoring & Diagnostics* for robots with OmniCore controllers, and ABB has to travel to site, travel expenses are not covered. The Extended Warranty period always starts on the day of warranty expiration. Warranty Conditions apply as defined in the Terms & Conditions.



#### Note

This description above is not applicable for option *Stock warranty* [438-8]

Option	Type	Description
438-1	Standard warranty	Standard warranty is 12 months from <i>Customer Delivery Date</i> or latest 18 months after <i>Factory Shipment Date</i> , whichever occurs first. Warranty terms and conditions apply.
438-2	Standard warranty + 12 months	Standard warranty extended with 12 months from end date of the standard warranty. Warranty terms and conditions apply. Contact Customer Service in case of other requirements.
438-4	Standard warranty + 18 months	Standard warranty extended with 18 months from end date of the standard warranty. Warranty terms and conditions apply. Contact Customer Service in case of other requirements.
438-5	Standard warranty + 24 months	Standard warranty extended with 24 months from end date of the standard warranty. Warranty terms and conditions apply. Contact Customer Service in case of other requirements.
438-6	Standard warranty + 6 months	Standard warranty extended with 6 months from end date of the standard warranty. Warranty terms and conditions apply.
438-7	Standard warranty + 30 months	Standard warranty extended with 30 months from end date of the standard warranty. Warranty terms and conditions apply.
438-8	Stock warranty	<p>Maximum 6 months postponed start of standard warranty, starting from factory shipment date. Note that no claims will be accepted for warranties that occurred before the end of stock warranty. Standard warranty commences automatically after 6 months from <i>Factory Shipment Date</i> or from activation date of standard warranty in WebConfig.</p> <div data-bbox="826 1753 888 1812" data-label="Image"> </div> <div data-bbox="909 1765 976 1796" data-label="Section-Header"> <h4>Note</h4> </div> <div data-bbox="820 1816 1452 1877" data-label="Text"> <p>Special conditions are applicable, see <i>Robotics Warranty Directives</i>.</p> </div>

## 2 Specification of variants and options

### 2.3 CARRIAGE BASICS (NUMBER 1/2/3/4)

### 2.3 CARRIAGE BASICS (NUMBER 1/2/3/4)

#### General introduction

The IRT 710 can be equipped with totally four carriages.

In the below lists, 1 & 2 & 3 & 4 means carriage 1, carriage 2, carriage 3 and carriage 4.

#### Bulkhead stand

Option	Description	Note
1705-1	Bulkhead stand <sup>i</sup>	For carriage number 1
1724-1		For carriage number 2
1743-1		For carriage number 3
1762-1		For carriage number 4

<sup>i</sup> The bulkhead is the interface mounting plate and protection box for the cable joints of flex cables and floor cables.

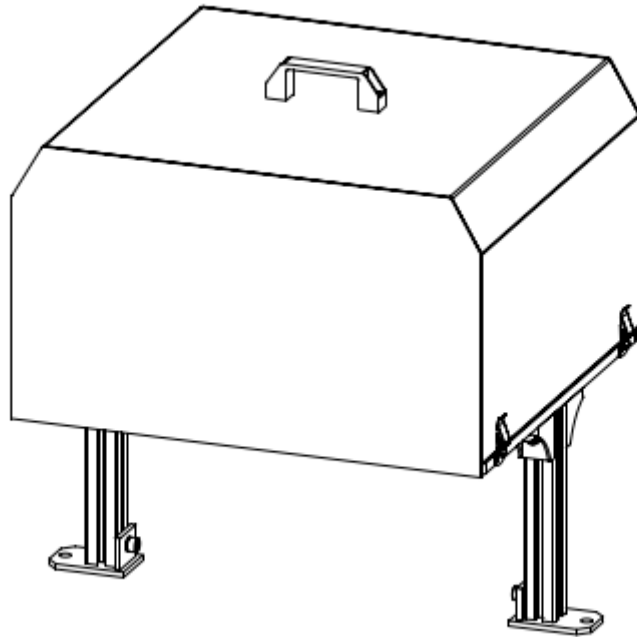

xx2200001488

*Continues on next page*

## 2 Specification of variants and options

### 2.3 CARRIAGE BASICS (NUMBER 1/2/3/4)

Continued

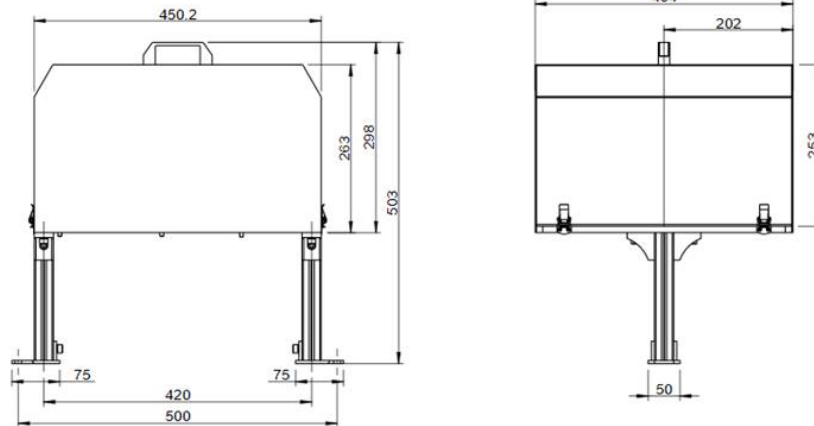

xx2200001489

#### Carriage lubrication

This option is mandatory option. If carriage quantity is 2/3/4, the option battery driven or 24V controlled will be automatically selected according to the selection of carriage 1.

Option	Description	Note
1706-1	Battery driven <sup>i</sup> (Default value)	For carriage number 1
1725-1		For carriage number 2
1744-1		For carriage number 3
1763-1		For carriage number 4

<sup>i</sup> The lubrication pump is driven by battery.

Option	Description	Note
1706-2	24V controlled <sup>i</sup>	For carriage number 1
1725-2		For carriage number 2
1744-2		For carriage number 3
1763-2		For carriage number 4

<sup>i</sup> The lubrication pump is driven by 24V signal.

#### Lubrication detection

If carriage quantity is 2/3/4, the option Lubrication detection will be automatically selected according to the selection of carriage 1.

Option	Description	Note
1707-1	Grease Detection sensor <sup>i</sup>	For carriage number 1
1726-1		For carriage number 2
1745-1		For carriage number 3
1764-1		For carriage number 4

<sup>i</sup> To check if the lubrication system works well, it is viable to take use of lubrication feedback system with IRT 710.

Continues on next page

## 2 Specification of variants and options

### 2.3 CARRIAGE BASICS (NUMBER 1/2/3/4)

Continued

#### Carriage calibration

This option is mandatory option. If carriage quantity is 2/3/4, the option Axis calibration will be automatically selected according to the selection of carriage 1.

Option	Description	Note
1708-1	Axis calibration	For carriage number 1
1727-1		For carriage number 2
1746-1		For carriage number 3
1765-1		For carriage number 4

Option	Description	Note
1708-2	Mechanical pin (Default value)	For carriage number 1
1727-2		For carriage number 2
1746-2		For carriage number 3
1765-2		For carriage number 4

#### Direction of travel

This option is mandatory option. For more details, see [Assembly of the manipulator on page 34](#).

If carriage quantity is 1, standard or mirrored is selectable.

If carriage quantity is 2 and the carriage number 1 select standard, then the carriage number 2 can be standard or mirrored mounting.

If carriage quantity is 2 and the carriage number 1 select mirrored, then the carriage number 2 must be mirrored.

If carriage quantity is 3 or 4, all carriages must be the same direction, standard or mirrored.

Option	Description	Note
1709-1	Standard (Default value)	For carriage number 1
1728-1		For carriage number 2
1747-1		For carriage number 3
1766-1		For carriage number 4

Option	Description	Note
1709-2	Mirrored NOT TOGETHER WITH: [1702-1] Additional 0.5 m	For carriage number 1
1728-2		For carriage number 2
1747-2		For carriage number 3
1766-2		For carriage number 4

Continues on next page

## 2 Specification of variants and options

### 2.3 CARRIAGE BASICS (NUMBER 1/2/3/4)

*Continued*

#### Valid for product

This option is mandatory option. The robot carriage and the transfer carriage cannot be selected at the same time.

Option	Description	Note
1710-1	IRB 4400	For carriage number 1
1729-1		For carriage number 2
1748-1		For carriage number 3
1767-1		For carriage number 4

Option	Description	Note
1710-2	IRB 460	For carriage number 1
1729-2		For carriage number 2
1748-2		For carriage number 3
1767-2		For carriage number 4

Option	Description	Note
1710-3	IRB 4600	For carriage number 1
1729-3		For carriage number 2
1748-3		For carriage number 3
1767-3		For carriage number 4

Option	Description	Note
1710-4	IRB 660	For carriage number 1
1729-4		For carriage number 2
1748-4		For carriage number 3
1767-4		For carriage number 4

Option	Description	Note
1710-5	IRB 6620	For carriage number 1
1729-5		For carriage number 2
1748-5		For carriage number 3
1767-5		For carriage number 4

Option	Description	Note
1710-6	IRB 6650S	For carriage number 1
1729-6		For carriage number 2
1748-6		For carriage number 3
1767-6		For carriage number 4

*Continues on next page*

## 2 Specification of variants and options

### 2.3 CARRIAGE BASICS (NUMBER 1/2/3/4)

Continued

Option	Description	Note
1710-7	IRB 6660	For carriage number 1
1729-7		For carriage number 2
1748-7		For carriage number 3
1767-7		For carriage number 4
Option	Description	Note
1710-8	IRB 6700	For carriage number 1
1729-8		For carriage number 2
1748-8		For carriage number 3
1767-8		For carriage number 4
Option	Description	Note
1710-9	IRB 760	For carriage number 1
1729-9		For carriage number 2
1748-9		For carriage number 3
1767-9		For carriage number 4
Option	Description	Note
1710-10	IRB 7600	For carriage number 1
1729-10		For carriage number 2
1748-10		For carriage number 3
1767-10		For carriage number 4
Option	Description	Note
1710-11	Transfer carriage same for all carriage	For carriage number 1
1729-11		For carriage number 2
1748-11		For carriage number 3
1767-11		For carriage number 4 REQUIRES: carriage 4 IRC5 Connection, [1770-2]

Continues on next page



## 2 Specification of variants and options

### 2.3 CARRIAGE BASICS (NUMBER 1/2/3/4)

*Continued*

#### Robot orientation

Option	Description	Note
1711-1	Inline	For carriage number 1 NOT TOGETHER WITH: [1710-11] Transfer carriage
1730-1		For carriage number 2 NOT TOGETHER WITH: carriage 2 [1729-11] Transfer carriage
1749-1		For carriage number 3 NOT TOGETHER WITH: [1748-11] Transfer carriage
1768-1		For carriage number 4 NOT TOGETHER WITH: [1767-11] Transfer carriage

Option	Description	Note
1711-2	45 Degrees	For carriage number 1 NOT TOGETHER WITH: [1710-11] Transfer carriage
1730-2		For carriage number 2 NOT TOGETHER WITH: carriage 2 [1729-11] Transfer carriage
1749-2		For carriage number 3 NOT TOGETHER WITH: [1748-11] Transfer carriage
1768-2		For carriage number 4 NOT TOGETHER WITH: [1767-11] Transfer carriage

Option	Description	Note
1711-3	90 Degrees	For carriage number 1 NOT TOGETHER WITH: [1710-11] Transfer carriage
1730-3		For carriage number 2 NOT TOGETHER WITH: carriage 2 [1729-11] Transfer carriage
1749-3		For carriage number 3 NOT TOGETHER WITH: [1748-11] Transfer carriage
1768-3		For carriage number 4 NOT TOGETHER WITH: [1767-11] Transfer carriage

*Continues on next page*

## 2 Specification of variants and options

### 2.3 CARRIAGE BASICS (NUMBER 1/2/3/4)

Continued

Option	Description	Note
1711-4	135 Degrees	For carriage number 1 NOT TOGETHER WITH: [1710-11] Transfer carriage
1730-4		For carriage number 2 NOT TOGETHER WITH: carriage 2 [1729-11] Transfer carriage
1749-4		For carriage number 3 NOT TOGETHER WITH: [1748-11] Transfer carriage
1768-4		For carriage number 4 NOT TOGETHER WITH: [1767-11] Transfer carriage

Option	Description	Note
1711-5	180 Degrees	For carriage number 1 NOT TOGETHER WITH: [1710-11] Transfer carriage
1730-5		For carriage number 2 NOT TOGETHER WITH: carriage 2 [1729-11] Transfer carriage
1749-5		For carriage number 3 NOT TOGETHER WITH: [1748-11] Transfer carriage
1768-5		For carriage number 4 NOT TOGETHER WITH: [1767-11] Transfer carriage

Option	Description	Note
1711-6	225 Degrees	For carriage number 1 NOT TOGETHER WITH: [1710-11] Transfer carriage
1730-6		For carriage number 2 NOT TOGETHER WITH: carriage 2 [1729-11] Transfer carriage
1749-6		For carriage number 3 NOT TOGETHER WITH: [1748-11] Transfer carriage
1768-6		For carriage number 4 NOT TOGETHER WITH: [1767-11] Transfer carriage

Continues on next page

## 2 Specification of variants and options

### 2.3 CARRIAGE BASICS (NUMBER 1/2/3/4)

*Continued*

Option	Description	Note
1711-7	270 Degrees	For carriage number 1 NOT TOGETHER WITH: [1710-11] Transfer carriage
1730-7		For carriage number 2 NOT TOGETHER WITH: carriage 2 [1729-11] Transfer carriage
1749-7		For carriage number 3 NOT TOGETHER WITH: [1748-11] Transfer carriage
1768-7		For carriage number 4 NOT TOGETHER WITH: [1767-11] Transfer carriage

Option	Description	Note
1711-8	315 Degrees	For carriage number 1 NOT TOGETHER WITH: [1710-11] Transfer carriage
1730-8		For carriage number 2 NOT TOGETHER WITH: carriage 2 [1729-11] Transfer carriage
1749-8		For carriage number 3 NOT TOGETHER WITH: [1748-11] Transfer carriage
1768-8		For carriage number 4 NOT TOGETHER WITH: [1767-11] Transfer carriage

#### Robot pedestal

Option	Description	Note
1712-1	250mm	For carriage number 1 NOT TOGETHER WITH: [1767-11] Transfer carriage
1731-1		For carriage number 2 NOT TOGETHER WITH: [1729-11] Transfer carriage
1750-1		For carriage number 3 NOT TOGETHER WITH: [1748-11] Transfer carriage
1769-1		For carriage number 4 NOT TOGETHER WITH: [1767-11] Transfer carriage

*Continues on next page*

## 2 Specification of variants and options

### 2.3 CARRIAGE BASICS (NUMBER 1/2/3/4)

Continued

Option	Description	Note
1712-2	500mm	For carriage number 1 NOT TOGETHER WITH: [1767-11] Transfer carriage NOT TOGETHER WITH: [1710-7] IRB 6660, [1710-9] IRB 760, [1710-10] IRB 7600
1731-2		For carriage number 2 NOT TOGETHER WITH: [1729-11] Transfer carriage NOT TOGETHER WITH: [1729-7] IRB 6660, [1729-9] IRB 760, [1729-10] IRB 7600
1750-2		For carriage number 3 NOT TOGETHER WITH: [1748-11] Transfer carriage NOT TOGETHER WITH: [1748-7] IRB 6660, 1748-9 IRB 760, [1748-10] IRB 7600
1769-2		For carriage number 4 NOT TOGETHER WITH: [1767-11] Transfer carriage NOT TOGETHER WITH: [1767-7] IRB 6660, [1767-9] IRB 760, [1767-10] IRB 7600
Option	Description	Note
1712-3	750mm	For carriage number 1 NOT TOGETHER WITH: [1767-11] Transfer carriage REQUIRES: [1710-3] IRB 4600
1731-3		For carriage number 2 NOT TOGETHER WITH: [1729-11] Transfer carriage REQUIRES: [1729-3] IRB 4600
1750-3		For carriage number 3 NOT TOGETHER WITH: [1748-11] Transfer carriage REQUIRES:[1748-3] IRB 4600
1769-3		For carriage number 4 NOT TOGETHER WITH: [1767-11] Transfer carriage REQUIRES: [1767-3] IRB 4600

Continues on next page

## 2 Specification of variants and options

### 2.3 CARRIAGE BASICS (NUMBER 1/2/3/4)

*Continued*

#### IRC5 Connection

This option is mandatory option.

Option	Description	Note
1713-1	No SMB box (Track motor resolver connector to Robot's FB7)	For carriage number 1 Not together with Valid for product 1 [1710-1] IRB 4400 , [1710-11] Transfer carriage
1732-1		For carriage number 2 Not together with Valid for product 2 [1729-1] IRB 4400
1751-1		For carriage number 3 Not together with Valid for product 3 [1748-1] IRB 4400
1770-1		For carriage number 4 Not together with Valid for product 4 [1767-1] IRB 4400 , [1767-11] Transfer carriage

Option	Description	Note
1713-2	1 Axis SMB box	For carriage number 1 REQUIRES: Valid for product 1 [1710-1] IRB 4400
1732-2		For carriage number 2 REQUIRES: Valid for product 2 [1729-1] IRB 4400
1751-2		For carriage number 3 REQUIRES: Valid for product 3 [1748-1] IRB 4400
1770-2		For carriage number 4 REQUIRES: Valid for product 4 [1767-1] IRB 4400 , [1767-11] Transfer carriage

Option	Description	Note
1713-3	3 Axis SMB box	For carriage number 1 REQUIRES: Valid for product 1 [1710-5] IRB 6620, [1710-6] IRB 6650S, [1710-7] IRB 6660, [1710-8] IRB 6700 and [1710-10] IRB7600
1732-3		For carriage number 2 REQUIRES: Valid for product 2 [1729-5], [1729-6], [1729-7], [1729-8] and [1729-10]
1751-3		For carriage number 3 REQUIRES: Valid for product 3 [1748-5], [1748-6], [1748-7], [1748-8] and [1748-10]
1770-3		For carriage number 4 REQUIRES: Valid for product 4 [1767-5], [1767-6], [1767-7], [1767-8] and [1767-10]

Option	Description	Note
1713-4	6 Axis SMB box	For carriage number 1 REQUIRES: Valid for product 1 [1710-11] Transfer carriage

*Continues on next page*

## 2 Specification of variants and options

### 2.3 CARRIAGE BASICS (NUMBER 1/2/3/4)

*Continued*

#### SMB Box stand

Option	Description	Note
1714-1	SMB Box stand (For fixing and protection)	For carriage number 1
1733-1		For carriage number 2
1752-1		For carriage number 3
1771-1		For carriage number 4

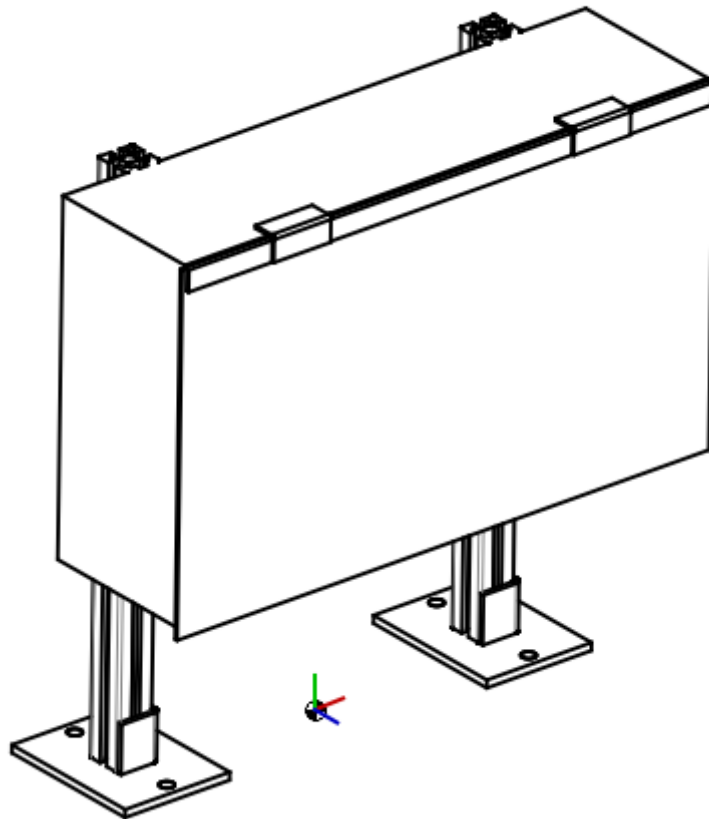

xx2200001490

*Continues on next page*

## 2 Specification of variants and options

### 2.3 CARRIAGE BASICS (NUMBER 1/2/3/4)

*Continued*

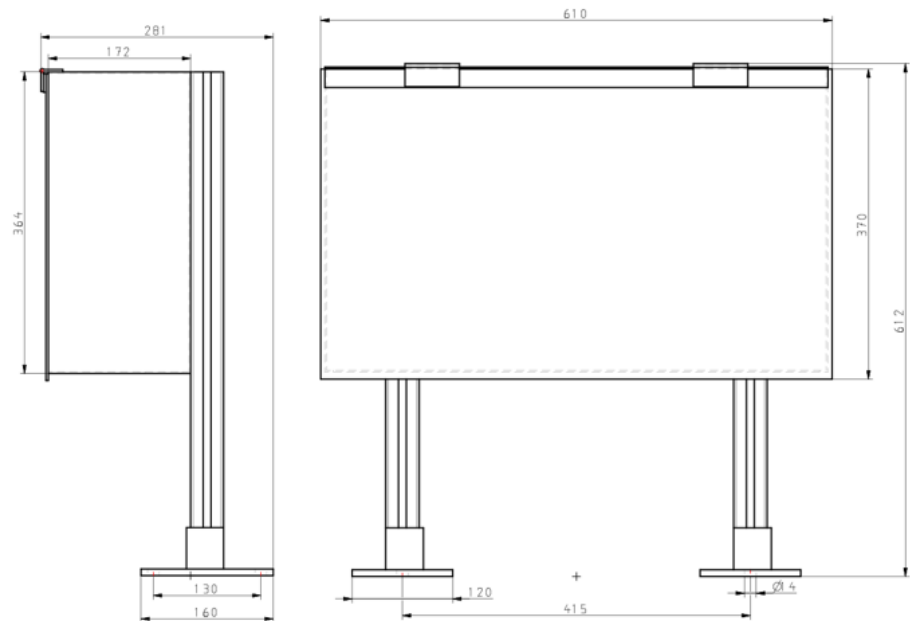

xx2200001491

#### Floor cables - IRC5 to Track

This option is mandatory option.

Option	Description	Note
1715-1	7m Track-floor cables	For carriage number 1 REQUIRES: IRC5 Connection 1 [1713-1]
1734-1		For carriage number 2 NOT TOGETHER WITH: CARRIAGE 2 [1729-11] Transfer carriage REQUIRES: carriage 2 IRC5 Connection 2 [1732-1]
1753-1		For carriage number 3 NOT TOGETHER WITH: CARRIAGE 3 [1748-11] Transfer carriage REQUIRES: carriage 3 IRC5 Connection [1751-1]
1772-1		For carriage number 4 REQUIRES: carriage 4 IRC5 Connection [1770-1]

*Continues on next page*

## 2 Specification of variants and options

### 2.3 CARRIAGE BASICS (NUMBER 1/2/3/4)

*Continued*

Option	Description	Note
1715-2	15m Track-floor cables	For carriage number 1 REQUIRES: IRC5 Connection 1 [1713-1]
1734-2		For carriage number 2 NOT TOGETHER WITH: CARRIAGE 2 [1729-11] Transfer carriage REQUIRES: carriage 2 IRC5 Connection 2 [1732-1]
1753-2		For carriage number 3 NOT TOGETHER WITH: CARRIAGE 3 [1748-11] Transfer carriage REQUIRES: carriage 3 IRC5 Connection [1751-1]
1772-2		For carriage number 4 REQUIRES: carriage 4 IRC5 Connection [1770-1]
Option	Description	Note
1715-3	22m Track-floor cables	For carriage number 1 REQUIRES: IRC5 Connection 1 [1713-1]
1734-3		For carriage number 2 NOT TOGETHER WITH: CARRIAGE 2 [1729-11] Transfer carriage REQUIRES: carriage 2 IRC5 Connection 2 [1732-1]
1753-3		For carriage number 3 NOT TOGETHER WITH: CARRIAGE 3 [1748-11] Transfer carriage REQUIRES: carriage 3 IRC5 Connection [1751-1]
1772-3		For carriage number 4 REQUIRES: carriage 4 IRC5 Connection [1770-1]

*Continues on next page*



## 2 Specification of variants and options

### 2.3 CARRIAGE BASICS (NUMBER 1/2/3/4)

*Continued*

#### Floor cables - IRC5 to SMB

This option is mandatory option.

Option	Description	Note
1716-1	7m Track-floor cables	For carriage number 1 REQUIRES: IRC5 Connection 1 [1713-2, 1713-3, 1713-4]
1735-1		For carriage number 2 NOT TOGETHER WITH: CARRIAGE 2 [1729-11] Transfer carriage REQUIRES: carriage 2 IRC5 Connection [1732-2] and [1732-3]
1754-1		For carriage number 3 NOT TOGETHER WITH: CARRIAGE 3 [1748-11] Transfer carriage REQUIRES: carriage 3 IRC5 Connection [1751-2] and [1751-3]
1773-1		For carriage number 4 REQUIRES: carriage 4 IRC5 Connection [1770-2] and [1770-3]

Option	Description	Note
1716-2	15m Track-floor cables	For carriage number 1 REQUIRES: IRC5 Connection 1 [1713-2, 1713-3, 1713-4]
1735-2		For carriage number 2 NOT TOGETHER WITH: CARRIAGE 2 [1729-11] Transfer carriage REQUIRES: carriage 2 IRC5 Connection [1732-2] and [1732-3]
1754-2		For carriage number 3 NOT TOGETHER WITH: CARRIAGE 3 [1748-11] Transfer carriage REQUIRES: carriage 3 IRC5 Connection [1751-2] and [1751-3]
1773-2		For carriage number 4 REQUIRES: carriage 4 IRC5 Connection [1770-2] and [1770-3]

*Continues on next page*

## 2 Specification of variants and options

### 2.3 CARRIAGE BASICS (NUMBER 1/2/3/4)

Continued

Option	Description	Note
1716-3	22m Track-floor cables	For carriage number 1 REQUIRES: IRC5 Connection 1 [1713-2, 1713-3, 1713-4]
1735-3		For carriage number 2 NOT TOGETHER WITH: CARRIAGE 2 [1729-11] Transfer carriage REQUIRES: carriage 2 IRC5 Connection [1732-2] and [1732-3]
1754-3		For carriage number 3 NOT TOGETHER WITH: CARRIAGE 3 [1748-11] Transfer carriage REQUIRES: carriage 3 IRC5 Connection [1751-2] and [1751-3]
1773-3		For carriage number 4 REQUIRES: carriage 4 IRC5 Connection [1770-2] and [1770-3]

#### Welding power cable

REQUIRES: IRB 7600, IRB 6700, IRB 6660, IRB 6650S, IRB 6620 and Carriage stroke less than 10m.

Option	Description	Note
1717-1	Welding power cable	For carriage number 1
1736-1		For carriage number 2
1755-1		For carriage number 3
1774-1		For carriage number 4

#### Servo-gun motor cable

REQUIRES: IRB 7600, IRB 6700, IRB 6660, IRB 6650S, IRB 6620 and Carriage stroke less than 10m.

Option	Description	Note
1718-1	Servo-gun motor cable	For carriage number 1
1737-1		For carriage number 2
1756-1		For carriage number 3
1775-1		For carriage number 4

#### CP/CS

Option	Description	Note
1719-1	Parallel NOT TOGETHER WITH: IRB 4400	For carriage number 1
1738-1		For carriage number 2
1757-1		For carriage number 3
1776-1		For carriage number 4

Continues on next page

## 2 Specification of variants and options

### 2.3 CARRIAGE BASICS (NUMBER 1/2/3/4)

*Continued*

Option	Description	Note
1719-2	DeviceNet NOT TOGETHER WITH: IRB 4400	For carriage number 1
1738-2		For carriage number 2
1757-2		For carriage number 3
1776-2		For carriage number 4

Option	Description	Note
1719-3	Ethernet/Profinet NOT TOGETHER WITH: IRB 4400	For carriage number 1
1738-3		For carriage number 2
1757-3		For carriage number 3
1776-3		For carriage number 4

Option	Description	Note
1719-4	CP/CS for IRB 4400 REQUIRES: IRB 4400, Carriage stroke less than 20m	For carriage number 1
1738-4		For carriage number 2
1757-4		For carriage number 3
1776-4		For carriage number 4

#### Fieldbus cables

Option	Description	Note
1720-1	Profinet cables	For carriage number 1
1739-1		For carriage number 2
1758-1		For carriage number 3
1777-1		For carriage number 4

Option	Description	Note
1720-2	Ethernet-IP cables	For carriage number 1
1739-2		For carriage number 2
1758-2		For carriage number 3
1777-2		For carriage number 4

Option	Description	Note
1720-3	Devicenet cables	For carriage number 1
1739-3		For carriage number 2
1758-3		For carriage number 3
1777-3		For carriage number 4

*Continues on next page*

## 2 Specification of variants and options

### 2.3 CARRIAGE BASICS (NUMBER 1/2/3/4)

Continued

#### Extra cable

Option	Description	Note
1721-1	One Power Supply 24V	For carriage number 1
1740-1		For carriage number 2
1759-1		For carriage number 3
1778-1		For carriage number 4

#### Media hose

Option	Description	Note
1722-1	1x DN12	For carriage number 1
1741-1		For carriage number 2
1760-1		For carriage number 3
1779-1		For carriage number 4

Option	Description	Note
1722-2	3x DN12 Carriage stroke less than 10m	For carriage number 1 REQUIRES: Valid for product 1 [1710-5], [1710-6], [1710-7], [1710-8] and [1710-10]
1741-2		For carriage number 2 REQUIRES: Valid for product 2 [1729-5], [1729-6], [1729-7], [1729-8] and [1729-10]
1760-2		For carriage number 3 REQUIRES: Valid for product 3 [1748-5] IRB 6620, [1748-6] IRB 6650S, [1748-7] IRB6660, [1748-8] IRB 6700 and [1748-10] IRB 7600
1779-2		For carriage number 4 REQUIRES: Valid for product 4 [1767-5], [1767-6], [1767-7], [1767-8] and [1767-10]

Option	Description	Note
1722-3	4x DN12 Carriage stroke less than 10m	For carriage number 1 REQUIRES: Valid for product 1 [1710-5], [1710-6], [1710-7], [1710-8] and [1710-10]
1741-3		For carriage number 2 REQUIRES: Valid for product 2 [1729-5], [1729-6], [1729-7], [1729-8] and [1729-10]
1760-3		For carriage number 3 REQUIRES: Valid for product 3 [1748-5] IRB 6620, [1748-6] IRB 6650S, [1748-7] IRB6660, [1748-8] IRB 6700 and [1748-10] IRB 7600
1779-3		For carriage number 4 REQUIRES: Valid for product 4 [1767-5], [1767-6], [1767-7], [1767-8] and [1767-10]

# Index

## A

- ambient humidity
  - operation, 16
  - storage, 16
- ambient temperature
  - operation, 16
  - storage, 16
- assembly instructions, 19
- Axis Calibration, 55
  - calibration tool
    - article number, 57
    - examining, 57
    - installation position, 59
  - overview of method, 54
  - protective cover and protection plug, 59

## C

- calibrating
  - robot, 55
- calibrating robot, 54
- calibration
  - standard type, 48
  - when to calibrate, 49
- calibration marks, 50
- calibration position
  - scales, 50
- calibration scales, 50

## F

- foundation
  - requirements, 12

## H

- humidity
  - operation, 16
  - storage, 16

## I

- instructions for assembly, 19

## O

- operating conditions, 16
- options, 85

## R

- requirements on foundation, 12
- robot
  - working range, 62

## S

- scales on track motion, 50
- standards
  - EN IEC, 18
  - EN ISO, 18
- storage conditions, 16
- sync marks, 50

## T

- temperatures
  - operation, 16
  - storage, 16

## V

- variants, 85

## W

- weight, 12
- working range
  - robot, 62







**ABB AB**

**Robotics & Discrete Automation**

S-721 68 VÄSTERÅS, Sweden

Telephone +46 (0) 21 344 400

**ABB AS**

**Robotics & Discrete Automation**

Nordlysvegen 7, N-4340 BRYNE, Norway

Box 265, N-4349 BRYNE, Norway

Telephone: +47 22 87 2000

**ABB Engineering (Shanghai) Ltd.**

Robotics & Discrete Automation

No. 4528 Kangxin Highway

PuDong New District

SHANGHAI 201319, China

Telephone: +86 21 6105 6666

**ABB Inc.**

**Robotics & Discrete Automation**

1250 Brown Road

Auburn Hills, MI 48326

USA

Telephone: +1 248 391 9000

**[abb.com/robotics](http://abb.com/robotics)**